

Montracon



the trailer for road transport



MT45 Machinery Carrier

OPERATOR HANDBOOK

(Rev 3 Edition)

www.montracon.com

CONTENTS

1. General	Page 3 - 7
2. Operating Instructions	Page 8 - 27
3. Air Suspension	Page 28 - 32
4. Brake System	Page 33 - 41
5. Electrical System	Page 42 - 46
6. Trailer Maintenance & Care	Page 47 - 61
7. Fault Finding	Page 62 - 72
8. Useful Contacts	Page 73

GENERAL INFORMATION

CONTENTS

1. Vehicle Identification	Page 4
2. General Description	Page 5
3. To the Driver	Page 5
4. Warranty & Claims Procedure	Page 6

This trailer has been manufactured by Montracon to:
BS EN ISO9001:2008
Registered for the design and manufacture of trailers
and rigid bodies.



VEHICLE IDENTIFICATION

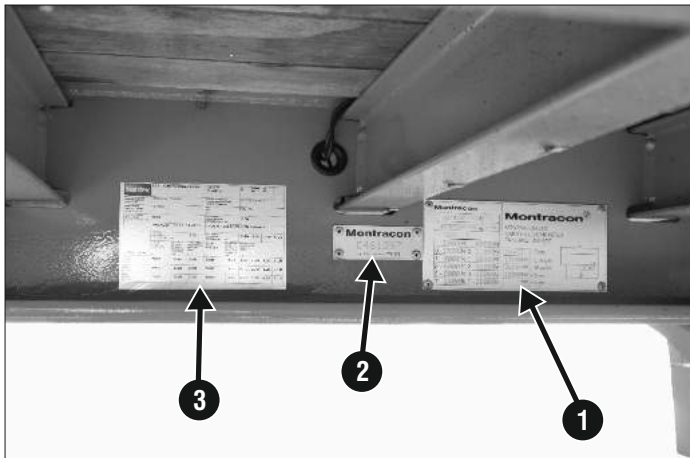

Each Montracon trailer has a unique Vehicle Identification Number (VIN) that, as well as other data, identifies its dimensions, its model type, its chassis number and subsequent weight information.

Figure 1

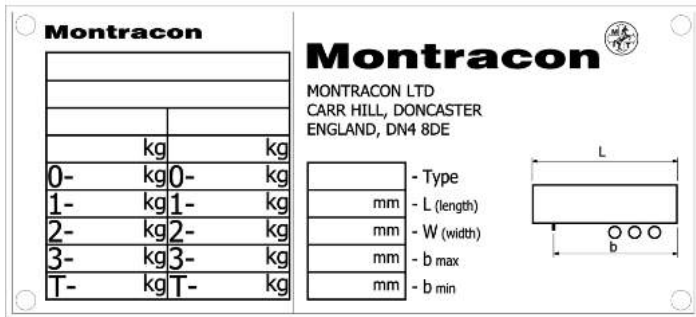

The trailer will also be fitted with a Montracon Ministry Plate showing the “C number” (Ministry number) which has been allocated to that trailer by VOSA before delivery to the Customer. This plate is usually fitted in the default position adjacent the landing legs on the near side of the trailer attached to the main chassis beam, an example of this plate is shown below.

Figure 2



The plate fixed near to the chassis plate is the load sensing valve data plate.

Figure 3

Haldex	EB+ ADR T0.EGG.094-04	2S/2M Stability	RIA 218	517mm 90H	RIA 328																																								
FABRIQUE / MANUFACTURER / FABRIGERESTELLE /Hersteller	Montracon	BRAND CALCULATION NO. / MARENBRANDRECHENUNGSNUMMER / CARTE DE PROBABILITE No.	2010241.1																																										
CHASSIS NUMBER / FABRIQUE / NUMERO DE CHASSIS	121895	TYPE / TYPE	semi-trailer																																										
TRAILER WEIGHT / PONDUS PROPRE / PNEUMATIQUE (t/m²)	0.30	PERMISSIBLE LIMIT / PONDUS MAXIMUM / LIMITE DE PROBABILITE (t/m²)	8.50																																										
UNLADEN / LEER / A VIDE [1.00 bar = 100 kPa]			LADEN / BELADEN / EN CHARGE [1.00 bar = 100 kPa]																																										
<table border="1"> <tr> <th>TR (daN)</th> <th>1.0</th> <th>1.6</th> <th>2.0</th> <th>2.30</th> <th>2.60</th> <th>3.00</th> <th>3.30</th> <th>3.60</th> <th>4.00</th> <th>4.50</th> <th>5.00</th> <th>5.50</th> <th>6.00</th> <th>6.30</th> </tr> <tr> <td>0</td> <td>0</td> <td>0</td> <td>0</td> <td>0</td> <td>0</td> <td>0</td> <td>0</td> <td>0</td> <td>0</td> <td>0</td> <td>0</td> <td>0</td> <td>0</td> <td>0</td> </tr> </table>			TR (daN)	1.0	1.6	2.0	2.30	2.60	3.00	3.30	3.60	4.00	4.50	5.00	5.50	6.00	6.30	0	0	0	0	0	0	0	0	0	0	0	0	0	0	0	<table border="1"> <tr> <th>TR (daN)</th> <th>0.70</th> <th>2.00</th> <th>4.50</th> <th>6.30</th> </tr> <tr> <td>0</td> <td>0</td> <td>0</td> <td>0</td> <td>0</td> </tr> </table>			TR (daN)	0.70	2.00	4.50	6.30	0	0	0	0	0
TR (daN)	1.0	1.6	2.0	2.30	2.60	3.00	3.30	3.60	4.00	4.50	5.00	5.50	6.00	6.30																															
0	0	0	0	0	0	0	0	0	0	0	0	0	0	0																															
TR (daN)	0.70	2.00	4.50	6.30																																									
0	0	0	0	0																																									

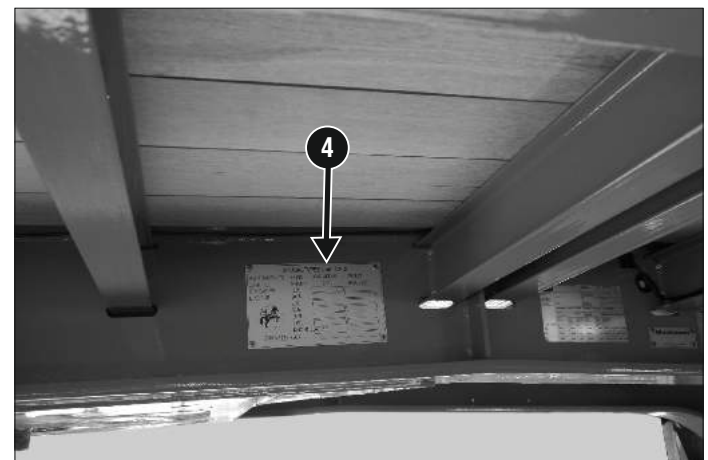

Figure 4

SPECIAL TYPES USE - CAT2			
MONTRACON LTD	SPEED	AXLE WEIGHT	TRAILER
CARR HILL	MPH/KPH	(Kg)	GROSS (Kg)
DONCASTER	12 / 20	10000	48000
ENGLAND	20 / 35	10000	48000
	25 / 40	10000	48000
	30 / 50	10000	48000
	35 / 55	10000	48000
	40 / 64	10000	48000
	KING PIN LOAD (Kg)		18000
	TYRES SIZE / INDEX		245/70R17.5 143/141J

This plate identifies the relevant weight information operating under Special Types Use.

GENERAL DESCRIPTION

This manual covers the main safety, operation and maintenance aspects of Montracon machinery carrier trailers. Before operating the trailer, this manual should be read and fully understood. It is important you familiarise yourself with the functions and operation of your trailer.

Montracon Limited reserves the right to make modifications to the design and/or technical specification of equipment without this resulting in making such modifications to products already sold. Whilst every effort is made to make sure descriptions, illustrations and specifications within this handbook are correct at the time of going to print, these are also subject to change.

TO THE DRIVER

It is your responsibility to read and comply with all safety instructions quoted in this handbook. Understand that your safety and the safety of others is measured by how you operate your vehicle.



SAFETY ALERT SYMBOL

This safety symbol is used to alert the driver/operator that SAFETY IS INVOLVED.

When ever you see the safety alert symbol used within this handbook carefully read the message that follows and be made aware to the possibility of serious injury.

**SAFETY IS IMPORTANT! Accidents can disable or kill.
Accidents are costly. Accidents can be avoided.**

WARRANTY

Every care and attention is taken in the production of your trailer/ chassis, however, should you feel that a claim on warranty should be made please contact the company without delay quoting the CHASSIS number stamped on the VIN plate. We cannot act on your claim without this number.

WARRANTY CLAIMS PROCEDURE

In the event of a problem occurring the following procedure should be adhered to, which will enable the claim to be processed efficiently and effectively.

Contact the Customer Service Department (during office hours) on Tel No. 01302 732500, Fax No. 01302 732503 prior to any repairs being commenced. Please ensure the following information is quoted before any claim can be processed.

1. Nature of problem
2. Detailed location of trailer
3. Date in service
4. Chassis No
5. Contact name and telephone number
6. Name of driver and telephone number
(if applicable)

Once we have this information, Montracon will either appoint an approved repairer to attend or make other arrangements for the work to be completed.

OWNERS RESPONSIBILITY

Due to the wide variance in the operating conditions of equipment, the owner and/or operator must exercise reasonable diligence in the maintenance and/or operation of this trailer. The owner must assume responsibility for proper care of their trailer, even while it is within the warranty period, including use of Montracon approved lubricants and other approved service parts.

Due to the numerous variations in braking systems and electrical circuits and their effects on the performance of the prime mover trailer combination as a whole, Montracon cannot guarantee or be held responsible for any incompatibility between the two vehicles.

Should there be the need to undertake a repair; it is up to the owner to release the trailer that has failed within the warranty period and for a reasonable amount of time to allow Montracon to carry out the necessary repairs. It is the owner's responsibility to deliver the trailer to the Montracon nominated premises in a clean condition for inspection and rectification, if applicable. Where the trailer has to be recovered to the nominated premises or if travel or cleaning costs are incurred in order to carry out repairs, the owner will be invoiced for the costs accordingly.

WARRANTY PERIODS

BPW AXLES

Years Months

		Years	Months
Axles	ECO	3	36
Suspension	ECO	3	36
Brakes		N/A	N/A
Disc Caliper/Roter		1	12
Spring Brake-(Brake chamber)		2	24
All ABS/EBS Sensors		1	12
Hub	ECO - This item must be registered with BPW by the operator - ECO PLUS	3	36
Autoslacks	BPW	2	24
Airbag	ECO MAX	1	12
	ECO PLUS	2	24
Shock Absorber	ECO MAX	2	24

HALDEX BRAKING SYSTEMS

Valve		2	24
ECU		3	36
Raise/Lower Valve		3	36
Park/Shunt Valve		3	36

ANCILLARY EQUIPMENT

Timber Floor			3
Chassis Construction		2	24
Valves		1	12
Electrics	(Bulbs Not Warrantable)	1	12
Landing Legs	MODUL	3	36
Paint (2 Pack)	Any damage must be repaired by a suitably qualified person. The trailer should be cleaned regularly and maintained to a suitable standard. (Terms & Conditions apply)	1	12
Winch		Refer to Winch Manufacturer	

TERMS AND CONDITIONS

If the trailer is found to be defective within the warranty period due to faulty materials or workmanship, then the defective part(s) will be repaired or replaced without charge for parts or labour subject to the following conditions:-

1. The work must be carried out by an authorised Montracon representative/repair agent.
2. The trailer must not have been neglected, misused or modified. Model designation and serial number plates/stampings must be intact.
3. The trailer must have been serviced as recommended in the Operator Handbook using only replacement parts, lubricants and fluids approved by Montracon. Suitable service records should be maintained at the owner's premises as evidence a specific service has been undertaken.
4. This warranty does not apply to those proprietary items whose manufacturers have their own Warranty Policy, e.g. Tyres, Axles, Braking Systems - refer to appropriate proprietary warranty policies for their warranty terms and conditions.
5. For more details of the company's warranty terms refer to the 'business terms' which form part of the purchase contract.

The warranty given on this trailer is expressly in lieu of and excludes (to the fullest extent permitted by Law) all other representations, conditions, guarantees or warranties expressed or implied. It shall be governed by UK Laws and all claimants under this warranty shall submit to the exclusive jurisdiction of the Courts of the UK.

Montracon reserves the right to update or change working policies, procedures and operating systems at any time.

OPERATING INSTRUCTIONS

CONTENTS

1. Bolt-in King Pin	Page 9
2. Coupling Trailer to Tractor	Page 9
3. Uncoupling Trailer from Tractor	Page 9
4. Landing Legs	Page 10
5. Checks Before Moving Off	Page 11
6. Know Your Vehicle	Page 12
7. Operating Controls	Page 13
8. Operating Instructions	Page 15

This section covers a wide variety of components that are used on Montracon trailers. Not all components will appear on one vehicle, therefore certain instructions contained herein will not apply. Where special instruction beyond the scope of this section is required, this will be supplied as supplementary information.

IF IN DOUBT, ASK!

BOLT-IN KING PIN

Check for correct positioning and security. Torque M14 bolts to 190Nm (140lb.ft)

COUPLING TRAILER TO TRACTOR UNIT

To correctly connect the tractor unit to the trailer carry out the following:

1. Ensure the trailer park brake is applied.
2. Set the trailer Landing Legs to the coupling height (see page 10, Landing Legs, Operation Instructions)

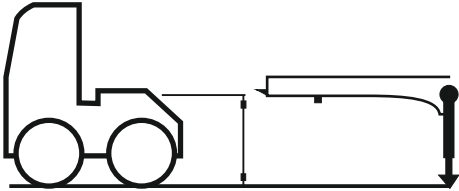

3. Check the tractor fifth wheel jaws are open (refer to tractor handbook). To assist trailer coupling, tilt tractor fifth wheel so that the rear end is sloping downwards.
4. Remove stabilising support, if applicable.
5. With the tractor and trailer correctly aligned, slowly reverse the tractor fully under the trailer fifth wheel plate - into the coupled position.
6. Ensure the combination is securely coupled by trying to move forward with the trailer parking brake applied. Visually check to ensure correctly coupled and coupling securely locked.
7. Connect the tractor's electrical and air couplings to their respective colour coded couplings on the front of the trailer. Open tractor airline 'shut off' cocks, if fitted. Couple hydraulic line(s), if applicable.

8. Raise the trailer support legs fully and secure correctly in the running position.
9. Test brakes for operation and carry out 'Checks Before Moving Off' (detailed on page 11).
10. Check trailer swing clearance to ensure trailer does not foul tractor unit.



WARNING:

Before moving away, always check the immediate vicinity of the vehicle. Ensure adequate visibility. Always comply with road traffic regulations. Check height clearance before travelling under bridges etc.

UNCOUPLING TRAILER FROM TRACTOR



WARNING:

Whether loaded or not, when uncoupled from the tractor unit some trailers with a long deck length forward of the support legs or rearward of the running gear may be unstable.

1. Ensure the trailer park brake is applied.
2. Lower the Landing Legs to the ground. (see page 10, Landing Legs, Operation Instructions)
3. Disconnect the air and electrical couplings from the trailer. Close tractor airline shut-off cocks, if fitted. Disconnect hydraulic lines(s), if applicable.
4. Unlock and release fifth wheel coupling. Slowly drive the tractor unit clear of the trailer.



LANDING LEGS



WARNING:

Never leave landing leg gearbox in neutral.

For the purpose of supporting the trailer when uncoupled and for setting the trailer to the required height when coupling.

The following instructions should be carried out on firm, level ground. If not, ensure the legs are positioned on suitable foot plates to prevent them from sinking.

NOTE: On vehicles fitted with legs operable from either side of the trailer, ensure the handle NOT being cranked is set in the NEUTRAL position before operating.

NOTE: The handle on the offside (RH) leg turns in the opposite direction to the handle on the nearside leg (i.e. opposite to the following instructions).

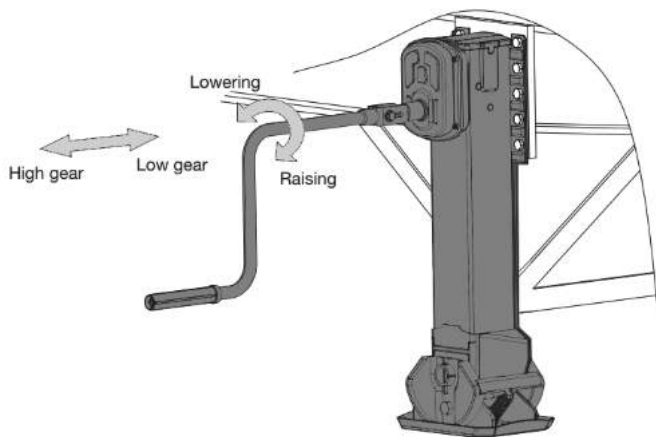

To set the legs for coupling:

Unclip the cranking handle and push shaft inwards to select low gear. Rotate handle and adjust trailer height so that the coupling plate is level or slightly lower (20mm max) if lead-up ramps are fitted.

Couple tractor unit as detailed and then raise the legs.

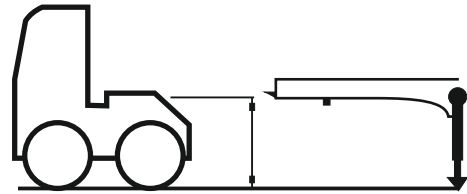

To lower the legs when uncoupling:

Unclip the cranking handle and pull shaft outwards to select high gear. Rotate handle clockwise until legs reach the ground - STOP - select low gear by pushing shaft inward and continue cranking until trailer is supported - Do not raise the trailer. Secure handle in stowed position and uncouple trailer as detailed.

To raise the legs once coupled:

Select high gear, rotate handle anticlockwise until legs are fully raised - Do not force beyond this position. Secure handle in stowed position.

CHECKS BEFORE MOVING OFF

The following checks should be carried out in addition to those quoted in 'Preventative Maintenance and Trailer Care' (Pages 46-60):

1. Electrical and Air Lines (and hydraulic lines where applicable)

All connections should be tight and clean. Connections should be well supported to prevent pinching or entanglement.

2. Lights and Markers

Check all lights and reflectors are positioned correctly, are clean and functioning properly. Replace damaged components promptly - it's illegal for components not to be functioning correctly.

Ensure relevant Emergency Cards or Markings are displayed (refer to Health and Safety information 'Dangerous Substances').

Ensure correct number plate is affixed to the trailer. NEVER use illegal markings.

3. Check Brake Operation

Allow system to pressurise, check tractor pressure gauges and if necessary run up until the tractor unit compressor exhausts or "blows off".

Try the service (foot) and third line (hand) controls (where applicable). Listen for air leaks during each application.

Carry out an anti-lock brake check, (see page 37).

4. Air Suspension

When fitted, allow air suspension to reach 'RIDE' height before moving off.

Ensure raise/lower or exhaust control (if fitted) is reset prior to moving. Some auto-reset systems require initial energising via the brake light circuit - press the brake pedal prior to moving.

5. Lift Axle

If axle is raised ensure the configuration is within legal plated weights.

6. Fifth wheel

Ensure fifth wheel is locked by pulling forward slightly with the trailer parking brake applied.



WARNING:

Always check that fifth wheel coupling is locked before moving off.

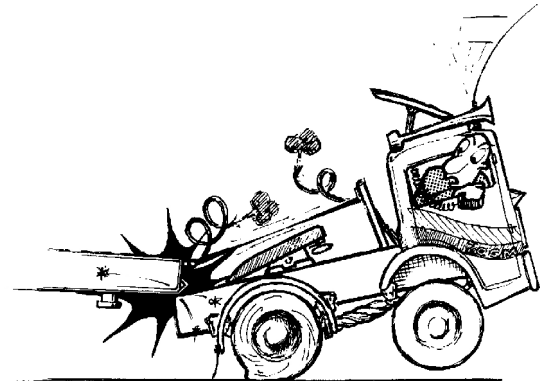

7. Raise Landing Legs

Check the landing legs are fully retracted and handle is stowed securely.



WARNING:

Ensure landing legs are fully raised before moving off.

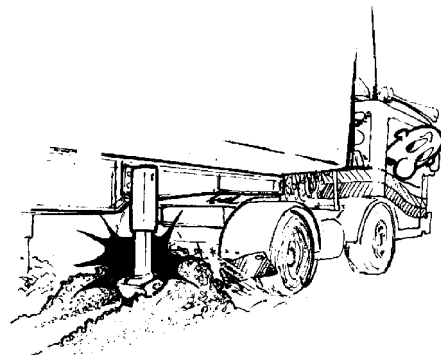

CHECKS BEFORE MOVING OFF

8. Check Wheels and Tyres

Generally, check the condition of all wheels and tyres, including spares, mudwings, and mud flaps/spray suppression. This includes correct tyre pressures as specified by the tyre manufacturer.

9. Check Payload

The amount and nature of the payload. If the load is a hazardous one, the driver should be aware of what to do in case of an emergency, i.e. fire or leakage. Check distribution and security of load. See “VOSA Guidance on load security April 2012” available at; www.gov.uk/government/organisations/vehicle-and-operator-services-agency

10. Ancillary Equipment

Where applicable, check the condition of all ancillary equipment and ensure it is correctly positioned/stowed.

11. Unsafe Equipment

Report all unsafe equipment before its condition becomes an operational hazard. Check the general condition of your vehicle e.g. load carrying area, sideraves, ladders, handrails, walkways, etc.

KNOW YOUR VEHICLE



WARNING:

Know the height, width and length of your vehicle.
Check the immediate vicinity of the vehicle.
Ensure adequate visibility.
Always comply with road traffic regulations.
Learn any special operating procedures.

OPERATING CONTROLS

ISOLATOR SWITCH

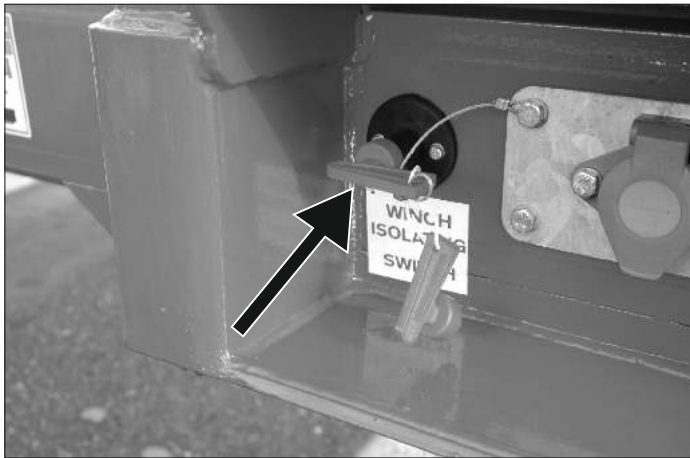

This switch isolates power to the winch. When in the off position the winch will not operate.

DUAL PURPOSE POWER PACK CONNECTOR

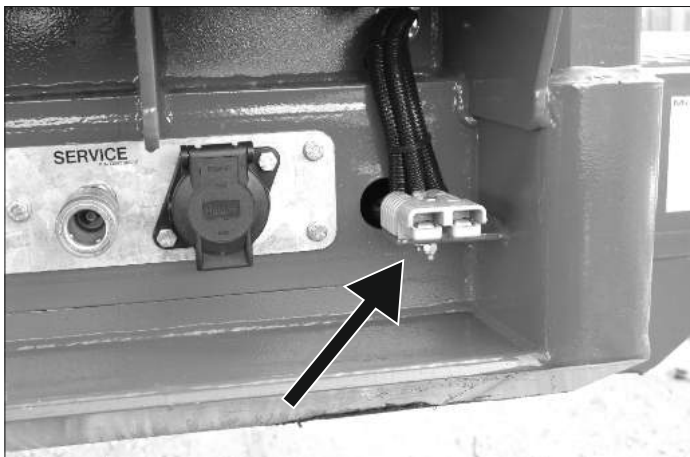

This connector provides power from the tractor unit to the Power Pack of the trailer thus allowing operation of the winch and ramp controls.

REAR RAMP CONTROLS

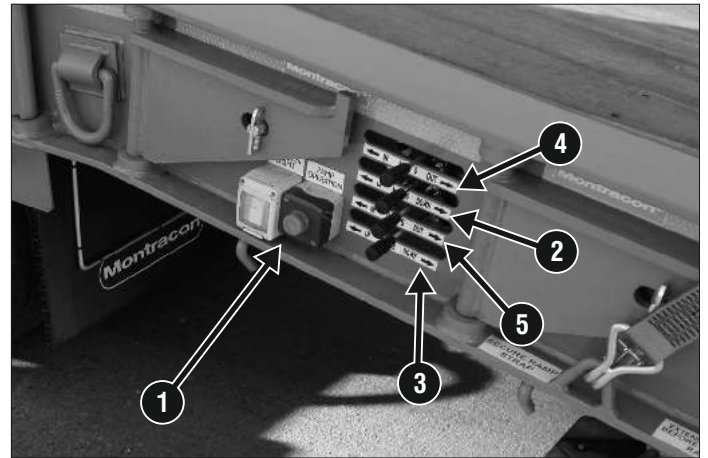

- 1. RAMP POWER PACK BUTTON
- 2. N/S RAMP RAISE/LOWER LEVER
- 3. O/S RAMP RAISE/LOWER LEVER
- 4. N/S RAMP SIDE SHIFT LEVER
- 5. O/S RAMP SIDE SHIFT LEVER

The rear ramp controls are strategically located in the side rave ensuring the operator has good visibility of the rear ramps and deployment area. See page 15-18 for correct operating procedure.

FRONT NECK RAMP CONTROLS

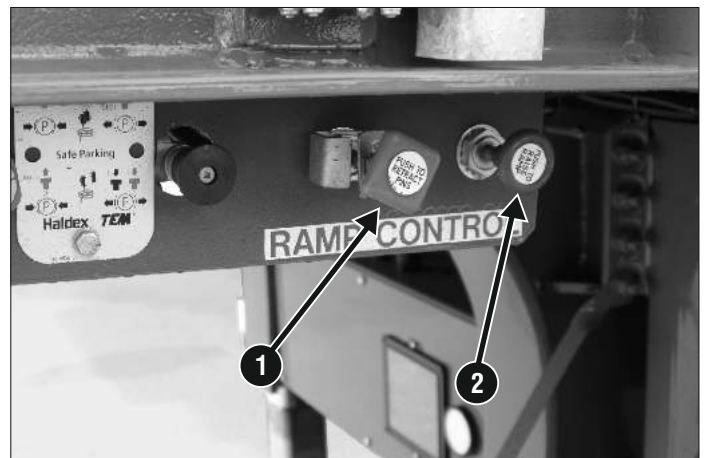

- 1. SUPPORT PIN CONTROL
- 2. NECK RAMP RAISE/LOWER CONTROL

The neck ramp is pneumatically raised/lowered by inflating or deflating a large airbag positioned underneath the neck ramp. See Page 19 for correct operating procedure.

LIFT AXLE (AS EQUIPPED)

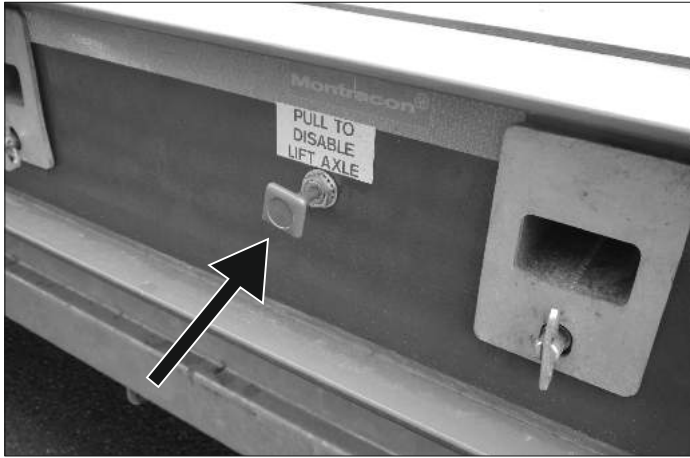

Pull to disable the lift axle functionality.

SWITCHES / BUTTONS (AS EQUIPPED)

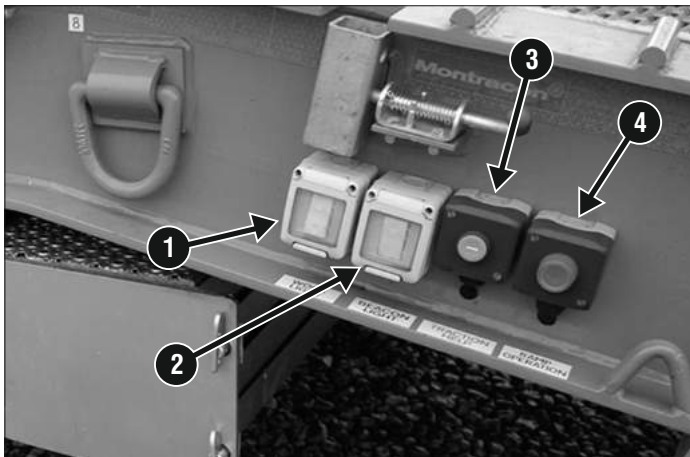

- 1. WORK LAMPS
- 2. ROTATING BEACON/STROBE LIGHTING
- 3. TRACTION HELP BUTTON
- 4. REAR RAMP ACTUATION BUTTON

SUSPENSION COMBINED RAISE / LOWER AND DUMP CONTROL

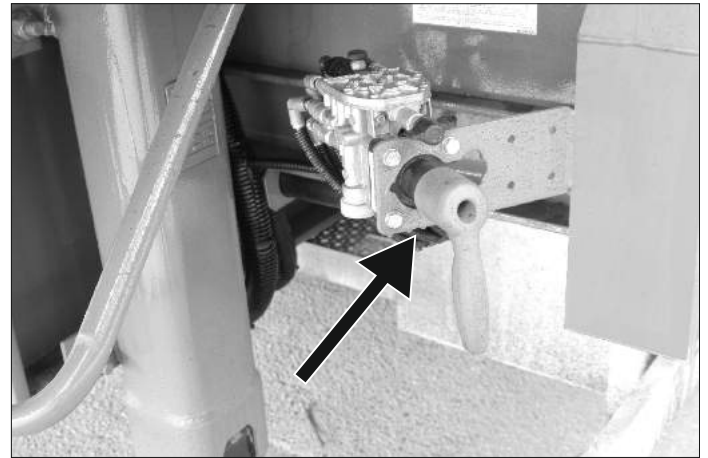

The raise/lower valve allows raising/lowering of the trailer by pressurising/depressuring the air suspension bellows. This control will also 'dump' the suspension if required. See page 31 for correct operating procedure.

PARKING BRAKE

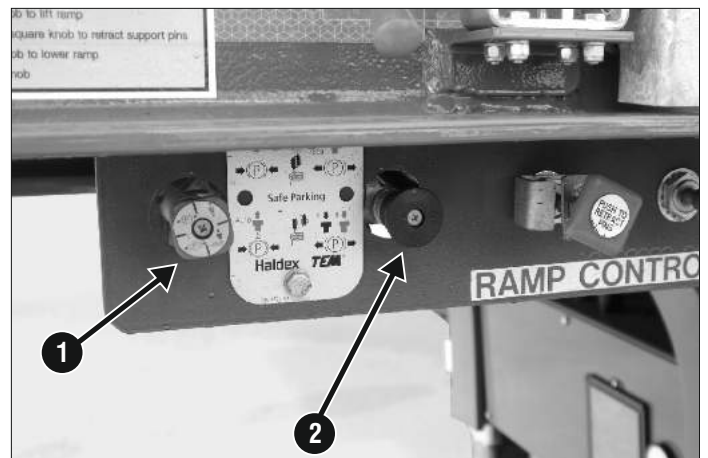

- 1. PARK BRAKE BUTTON
- 2. TRAILER BRAKE RELEASE BUTTON

OPERATING INSTRUCTIONS

HYDRAULIC RAMP OPERATION

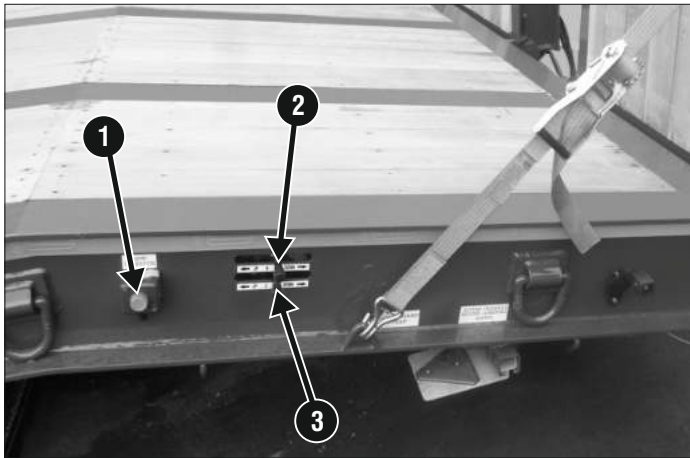

- 1. RAMP POWERPACK ACTUATION BUTTON
- 2. N/S RAMP RAISE/LOWER LEVER
- 3. O/S RAMP RAISE/LOWER LEVER

1. Position the trailer on a firm, flat level surface.
2. Apply the trailer parking brake and connect the power pack connector (4).

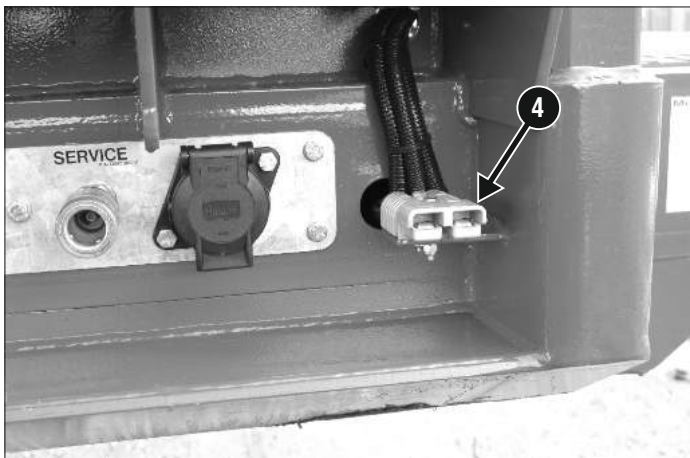

3. Lower the steady legs, (see page 16 for correct procedure).
4. Lower the air suspension using the raise/lower control on the trailer suspension, (see page 31 for correct procedure).

5. Extend reflective triangles before lowering ramps.
6. Undo the ramp straps and store the strap in a suitable location, near to the trailer.



WARNING:

Check the area, make sure it is clear and no-one is likely to walk around the back of the trailer.

7. Whilst pressing the ramp actuation button (1), operate the relevant control lever (2 or 3) to lower each ramp to the ground.

NOTE: If Flip-Toe ramps are fitted, as the ramps are lowered the toe-end of the ramp will automatically unfold.

8. Once loading is complete, raise the ramps to the vertical position and secure using the ramp straps.
9. Raise the trailer suspension to the normal ride height.
10. Return the reflective triangles to their stored position.
11. Put the folding steady legs back into the stored position.



WARNING:

Make sure the steady legs are stored and secure before commencing travel.

FOLDING STEADY LEGS (STANDARD FITMENT)

IMPORTANT: Always make sure the steady leg is deployed before loading/unloading.

1. Pull on the spring loaded locking pin.



2. Allow the support leg to swing down into the vertical position and store the locking pin in the parking hole.

3. To raise the leg; swing the leg up by hand and return the spring loaded locking pin to its home position.

HYDRAULIC STEADY LEGS (AS EQUIPPED)

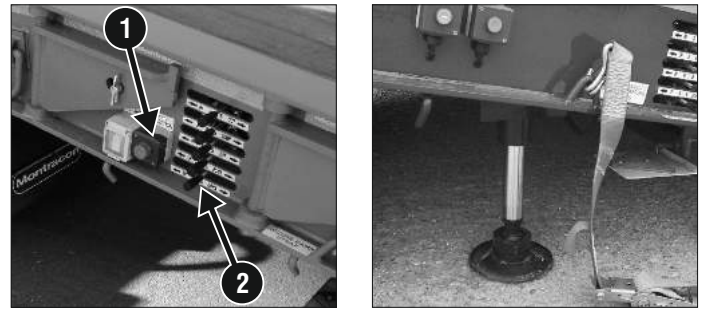

1. Whilst pressing the actuation button (1) operate the steady leg control lever (2) to raise/lower the leg as required.

IMPORTANT: Always make sure the hydraulic steady leg is in contact with the ground before loading/unloading.

FLIP-TOE RAMP OPERATION



As the ramps are lowered the toe-end of the ramp will automatically unfold.

LOADING/UNLOADING



WARNING:

Always abide legal weight restrictions when loading. Understand the axle load limitations and the limitations of the tractor unit.



Always ensure a straight-line loading angle prior to commencing loading/unloading operations.

IMPORTANT: Side loading should not be undertaken under any circumstances.

IMPORTANT: When loading / unloading ensure the steady legs are lowered before lowering the trailer suspension. The steady legs must be used at all times as well as lowering the suspension.

Load Lashing

IMPORTANT: Rope hooks should not be used to anchor loads. Rope hooks are not subject to constructional standards and so could vary in strength. Lashing rings should be used at all times to secure the load to the bed of the trailer. If in doubt consult Department of Transport's Code of Practice on "Safety of Loads on Vehicles for the correct loading/unloading and securing of load regulations.

Care of Deck Lashing Rings

Deck lashings must be kept free from foreign objects, ie. stones, gravel, nuts & bolts, sludge etc. Deck lashings are designed to work freely and must be kept "home", in the recess of the deck. Under no circumstances should the lashing rings be left up and open when not in use.



The above shows a deck mounted lashing ring left open and driven over, this is extremely dangerous, the machine could slip and cause it to leave the side of the trailer. In the open position lashings can be a trip hazard.

Always check the condition of each lashing ring for damage and replace as necessary.

HYDRAULIC RAMP WIDTH ADJUSTMENT (SIDE SHIFT RAMPS)

IMPORTANT: The side-shift ramps must only be moved sideways in the vertical position. Trying to slide the ramps once they are lowered will increase the load bearing on the slide mechanism and subsequent damage may occur.

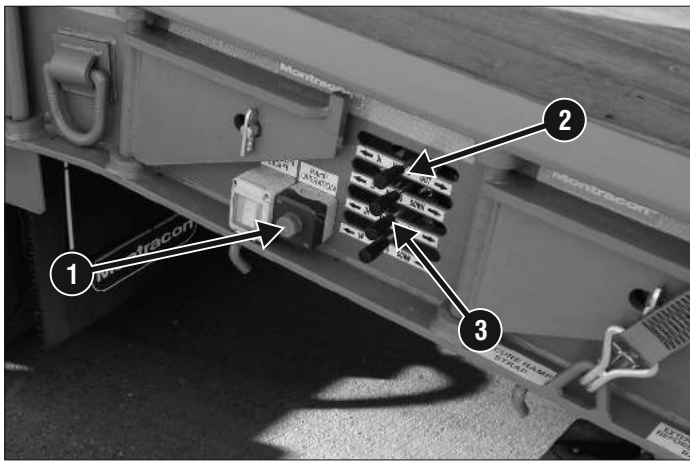

- 1. RAMP ACTUATION BUTTON
- 2. N/S RAMP SIDE SHIFT LEVER
- 3. O/S RAMP SIDE SHIFT LEVER

1. Position the trailer on a firm, flat level surface.

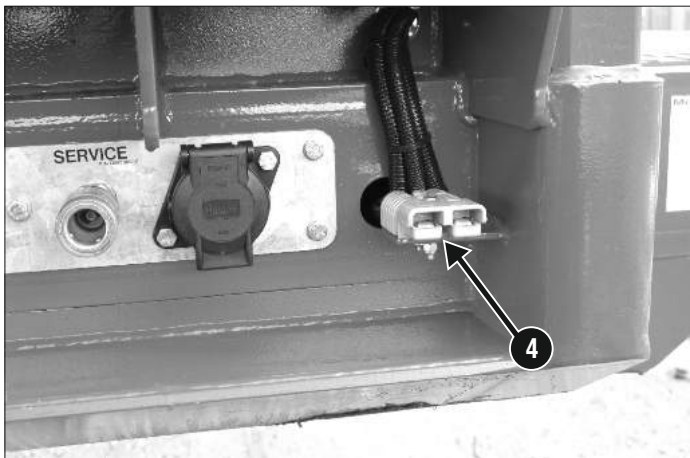

2. Apply the trailer parking brake and connect the power pack connector (4).

3. Lower the steady legs, (see page 16 for correct procedure).

4. Lower the air suspension using the raise/lower control on the trailer suspension, (see page 31 for correct procedure).

5. Extend reflective triangles.

6. Unlatch the locking pin in the slider plate (5).

7. Slacken, but do not remove the ramp straps.



8. Undo the ramp straps and store the strap in a suitable location, near to the trailer.



WARNING:

Check the area, make sure it is clear and no-one is likely to walk around the back of the trailer.

9. Whilst pressing the ramp actuation button (1) operate the relevant control lever (2 or 3) to slide the ramp to the desired position.

10. Continue to press the ramp actuation button and operate the relevant control lever to lower each ramp to the ground.

IMPORTANT: After raising the ramps slide them back into the normal travel position. **Make sure the slider plate locking pins are engaged and locked before commencing travel.**

FRONT NECK RAMP

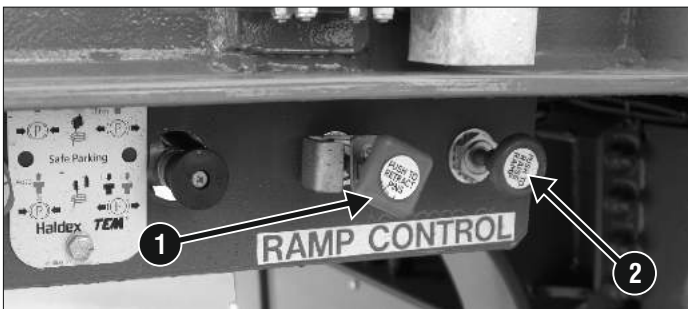

- 1. SUPPORT PIN CONTROL
- 2. NECK RAMP RAISE/LOWER CONTROL

The neck ramp is pneumatically operated via a large airbag positioned underneath the neck ramp. The neck ramp is raised and lowered by inflating and deflating the air bag accordingly.

To lift the ramp:

1. Push in the support pin control (Red Button) to retract the support pins and rotate the button to lock the valve in position.
2. Push in the neck raise/lower control (Blue Button), the air bags will inflate and raise the ramp to full height.
3. Once the ramp is at full height twist the support pin control thus allowing it to spring from the locating position. The support pins will extend out from the neck (under the neck ramp).

4. When the support pins are fully extended, pull out the neck ramp raise/lower valve to lower the ramp and rest on the support pins.

IMPORTANT: Always make sure the neck ramp is lowered and resting on the support pins before loading onto the neck area.

To lower the ramp:

1. Push in the neck raise/lower control (Blue Button) to raise the ramp off the support pins.
2. Push in the support pin control (Red Button) to retract the support pins and rotate the button to lock the valve in position.
3. Pull out the neck raise/lower control (Blue Button) to lower the neck ramp.

CLIP-ON RAMPS (AS EQUIPPED)

As an alternative to the hydraulically powered loading ramps, clip on ramps may have been specified.



WARNING:

Clip-on ramps have a load rating. Make sure the correct ramps are used to suit the load.

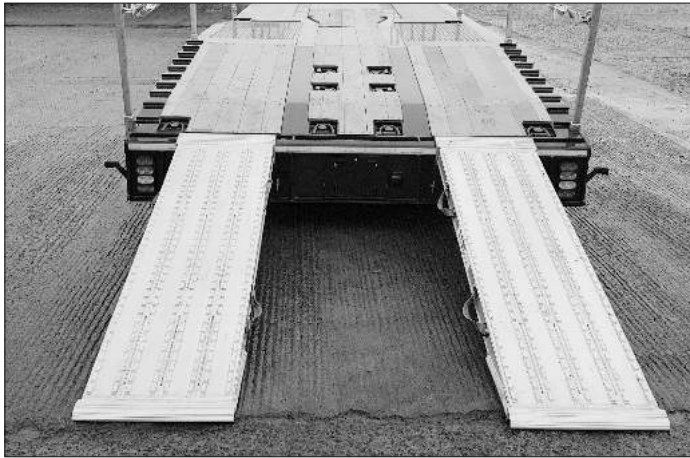

1. REAR CLIP-ON RAMPS



2. NECK CLIP-ON RAMPS

Always store the ramps safely before commencing travel.



3. RAMP STOWAGE, SIDE LOADING OPTION



4. RAMP STOWAGE, REAR LOADING OPTION

GRIP BARS



Grip bars must be kept free from foreign objects and sludge, dirt etc. Periodically check for damage. Repair or replace as necessary.

WIDENING THE LOAD SPACE

IMPORTANT: Outriggers are to be used solely to give extra stability when transporting wide loads. Under no circumstances should a full load be supported by the outriggers. Full loads should be secured onto the main deck of the trailer.

NOTE: Outrigger timbers are available as an optional extra to place over the outriggers.

Pull-Out Outriggers (as equipped)



The pull-out outriggers extend the deck of the trailer by a maximum 600mm. The outriggers have two stages extending to 300mm and 600mm.

To extend; place your hand inside the out rigger and lift the release mechanism. Lift and pull the out rigger until it hits the first stop. Repeat to fully extend.

Swing-Out Outriggers (as equipped)



The swing-out outriggers extend the deck of the trailer by a maximum 600mm.

To extend; release the locking pin (1) and simply swing the outrigger into position.

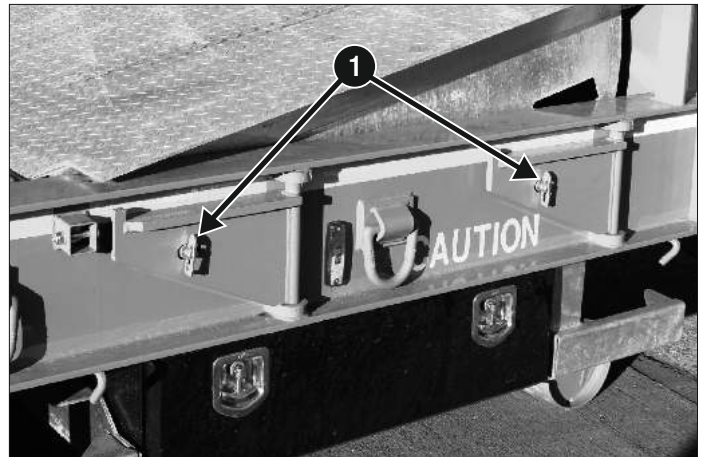

SAFETY FALL ARREST & WALKWAY SYSTEM

With ever increasing emphasis now being placed on Health and Safety the Fall Arrest & Safety Walkway option(s) are designed to help reduce avoidable accidents when walking on the deck of the trailer.



PULL OUT HI-VIS HAND RAILS AND DRIVER FALL ARREST PROTECTION



GRIPPED WALKWAYS ALLOW THE DRIVER TO MAINTAIN ACCESS ALONG THE DECK EVEN WHEN THE LOAD TAKES UP THE FULL WIDTH OF THE TRAILER BED

To deploy the walkway system:

1. Slacken the edge protection straps.
2. Release the fall arrest posts and lock in the outward position.
3. Remove the walkway decking panels from the storage position and lay at the side of the trailer starting at the front with number 1.

NOTE: Keep the panels closer to avoid creating a trip hazard.

NOTE: Each panel is numbered and should be laid out in sequential number order.

4. Once the panels are out, install on the trailer ensuring that each panel locates with the round locking bar (1) under each panel.

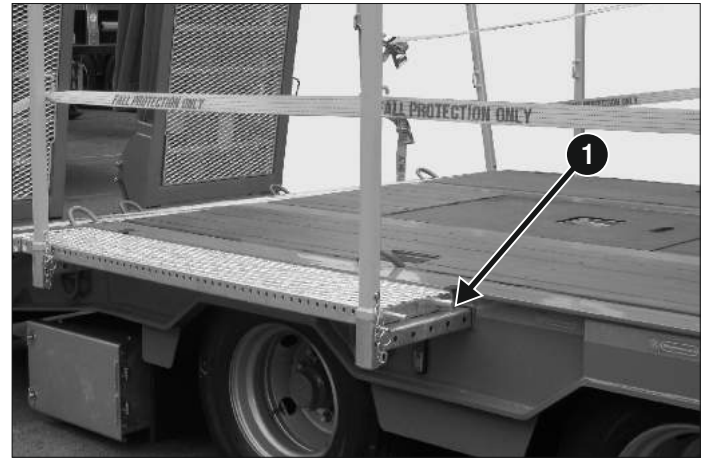

5. When all the panels are in place, retighten the edge protection straps.

To store the walkway system:

1. Slacken the edge protection straps.



2. Remove and locate the walkway panels back in the storage rack.
3. Release the fall arrest posts push fully inwards and lock into position.
4. Retighten the edge protection straps.

PULL OUT MARKERBOARDS (AS EQUIPPED)



Use markerboards as per highway code regulations.

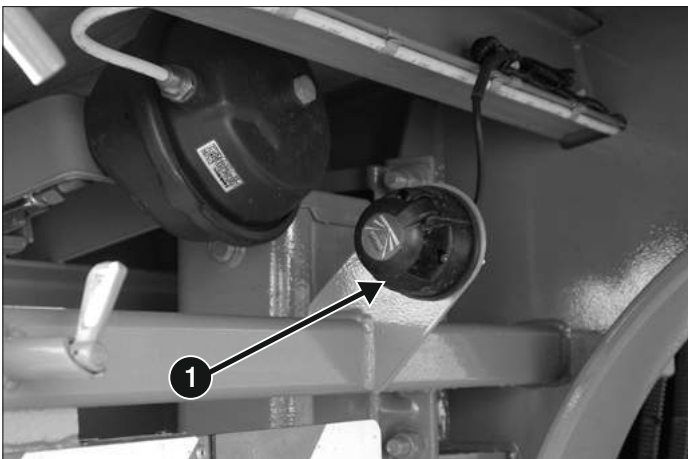

An electrical socket (1) is located under the side rail to provide power to markerboards equipped with a marker lamp.

PULL OUT TRIANGLES



Before operating the rear ramps, make sure the pull-out triangles are extended.

TIMBER OUTRIGGERS & STOWAGE (AS EQUIPPED)



If your trailer comes with timber outriggers, always store outriggers safely before commencing travel.

TOOL BOXES (AS EQUIPPED)

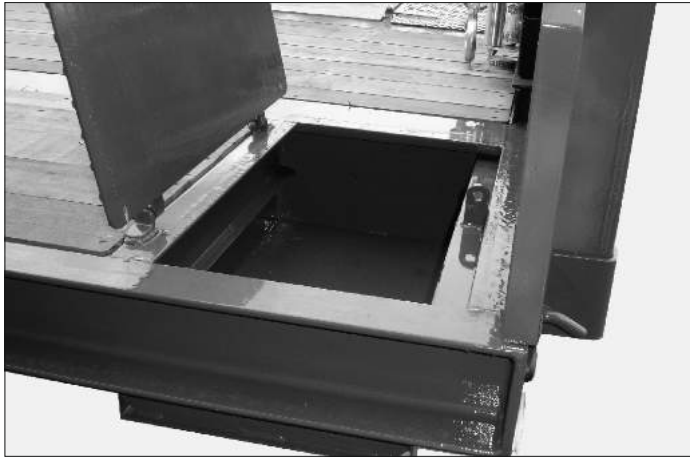

NOSE MOUNTED INTEGRAL TOOL BOXES



CHASSIS MOUNTED TOOL BOXES

WINCH (AS EQUIPPED)

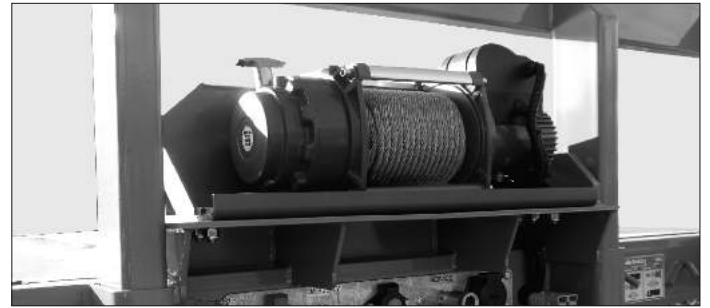

Please refer to the relevant winch manufacturers operating instructions for information and advice on the correct winch operation and any relevant safety notices.

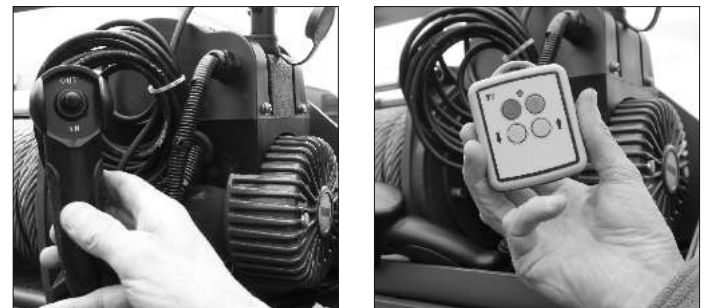

The winch can be operated using one of two control methods supplied:

1. Hand held radio remote control unit.
2. Plug in wander lead, socket normally located on the winch, and/or on the nearside rear of the trailer.

MAINTENANCE COVER



A hardwood maintenance cover in the floor of the trailer is provided to gain access to the levelling valve, EBS valve and auxiliaries should the need arise.



ELECTRO-HYDRAULIC POWER PACK ACCESS

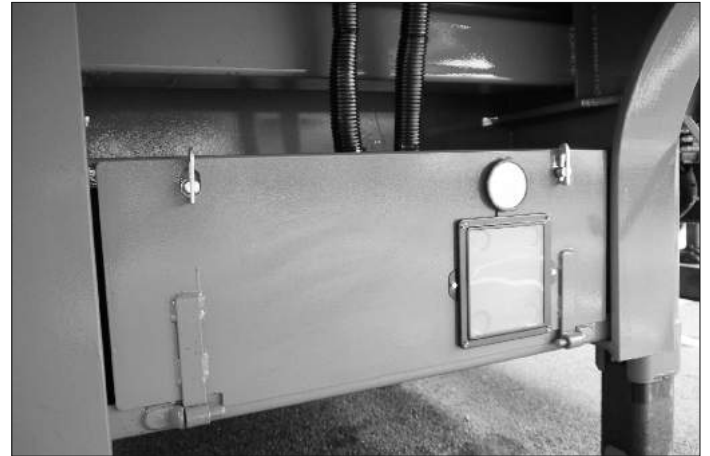

The electro-hydraulic power pack is mounted between the two main beams in the neck area of the trailer, along with the hydraulic oil reservoir. Lower the cover to gain access.



Check the oil level in the reservoir at weekly intervals. Oil should be halfway up the dipstick. Replenish as required. Correct grade oil is 32 grade.

NOTE: Make sure the ramps are in the transport position prior to checking the oil level.

HEADBOARDS (AS EQUIPPED)

Numerous headboard configurations are offered to suit customer requirement.

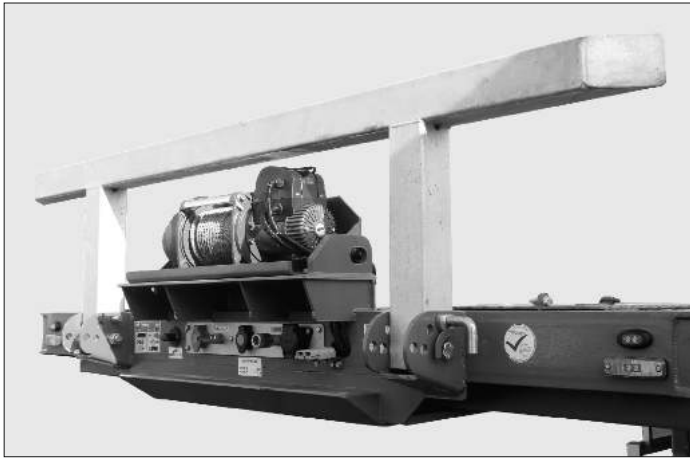

HINGE TYPE: Can be adjusted to suit the load being carried.

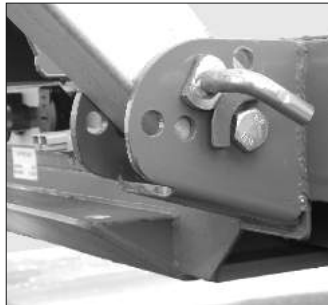
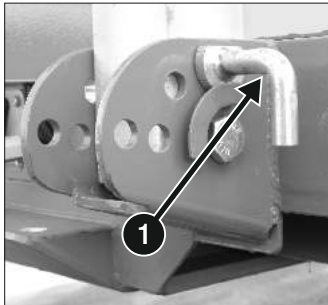

To change position of the headboard, remove the locking pin (1) from its current position. Raise or lower the headboard to the new position and re-install the locking pin.



REMOVABLE TYPE: Is secured in sockets and held in position via locking bolts. Removing the bolts will allow the headboard to be lifted from the sockets.

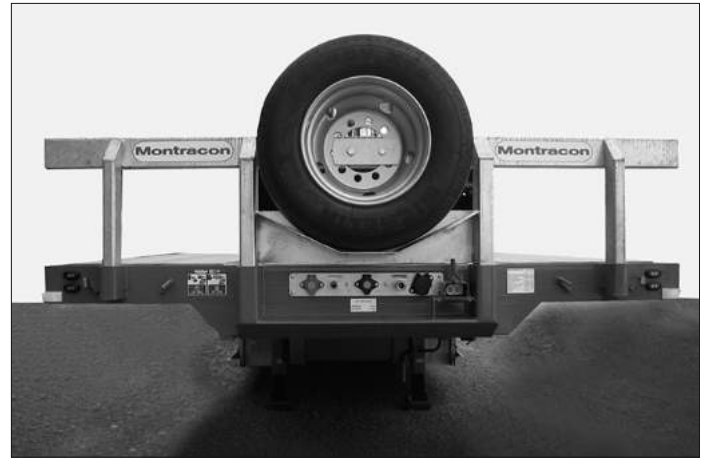

SPARE WHEEL CARRIER: Remove the securing bracket to access the spare wheel.



FIXED HEAVY DUTY HEADBOARD: EN12642XL rated headboard for heavy duty applications.

HEADBOARD WITH SLIDING PEDESTRIAN ACCESS (AS EQUIPPED)

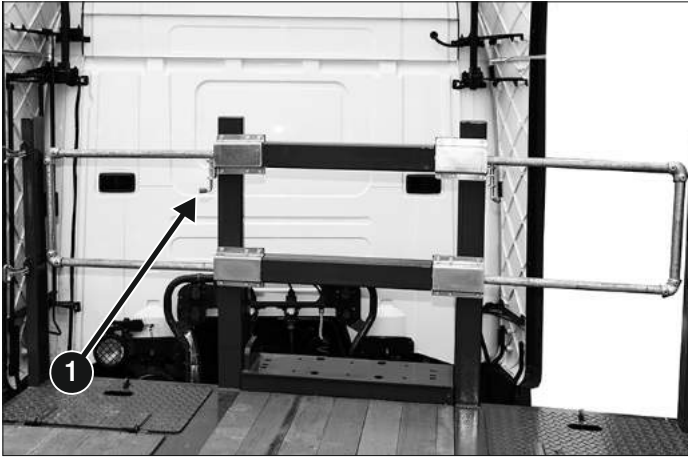

For easy pedestrian access onto the bed of the trailer release the locking pin (1).



Maintain the correct 3 points of contact when accessing the trailer bed.



Slide the barrier across and lock into position.

AIR SUSPENSION

CONTENTS

1. General Information	Page 29
2. Before Commencing a Journey	Page 29
3. Identification	Page 29
4. Load-Sensing Valve	Page 29
5. Height Control Valve	Page 30
6. Raise/Lower Valve	Page 31
7. Lift Axle	Page 32

This section covers a wide variety of components that are used on Montracon trailers. Not all components will appear on one vehicle, therefore certain instructions contained herein will not apply. Where special instruction beyond the scope of this section is required, this will be supplied as supplementary information.

IF IN DOUBT, ASK!

GENERAL INFORMATION

Air suspension is specifically designed to give superb ride characteristics and trouble free operation. A flexible link (trailing arm) suspension, the trailing arms pivot on front mounted rubber bushed hanger brackets welded to the chassis, with the axle secured via cast steel seat and an air spring completing the link to the rear. Shock absorbers provide the damping required for the best possible performance. Air required for the springs is fed from the air reservoirs, from where it is controlled by valves.

BEFORE COMMENCING A JOURNEY

The following checks should be carried out in addition to 'Checks before moving off' (Operating Instructions, P11).

1. Allow the engine to run until the correct working pressure in the brake system and suspension system is obtained.
2. Visually check if all the air bellows are pressurised.
3. Make sure that the normal ride height is attained for the air suspension unit.

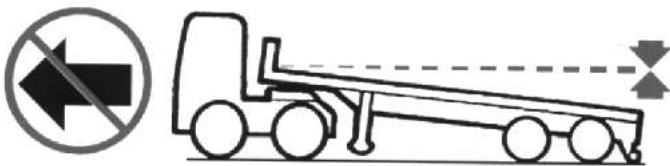

WARNING:

Damage might result if vehicles are driven at high speeds or on bad roads with de-pressurised air bellows.

IDENTIFICATION

The air suspension units fitted to Montracon trailers have a manufacturer's identification plate, which is normally situated either to the centre of the axle tube or on the hanger bracket.

Information contained on the plate will be required when ordering replacement parts or for service / warranty purposes.

Refer to Manufacturer's literature for more detailed information.

LOAD SENSING VALVE

Load sensing is incorporated in trailers having an electronic braking system (EBS). On vehicles without an electronic braking system, ie. trailers with air suspension and pneumatic load sensing, the brake force is governed by the air pressure in the air springs which increases with vehicle weight, ie. 'automatic load-controlled brake system.'

For ABS systems, the load sensing valve is mounted centrally on the chassis forward of the front axle.

For the EBS system, the load sensing valve is integrated into the main braking module.



WARNING:

DO NOT tamper with the factory valve settings.

HEIGHT CONTROL VALVE (Air Levelling or Ride Height Valve)

All Montracon trailer air suspensions have a height control valve and all come with a recommended ride height setting in millimetres (mm). For the suspension to operate correctly, the height control valve must be maintained as shown below (Fig.1).

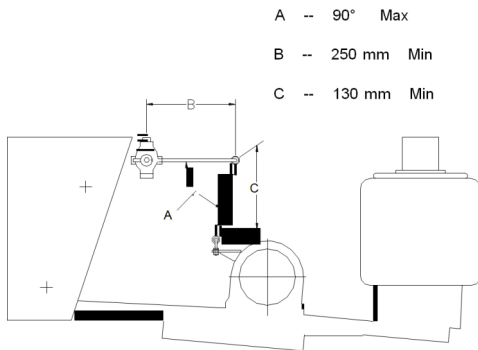

1. The trailer should be positioned on level ground and either connected to the tractor unit or set at the correct kingpin height.
2. All trailer brakes should be OFF.
3. There should be an air supply to the suspension unit of at least 6.5 bar.
4. The height control valve should be positioned in the middle of the sensed axle.
5. If the trailer is fitted with a lift axle, it should be in the down position.
6. Length of the horizontal and vertical rods (see Fig 1).
7. Check that the height control valve is piped correctly ie. one port supplies the nearside suspension bags, the other the offside bags. Air to the height control valve is supplied via a second reservoir.

8. The horizontal rod is fitted in relation to the arrow on the height control valve boss.

9. Ride height is measured from the centre of the axle beam to the underside of the chassis main member.

STANDARD RAISE/LOWER VALVE



WARNING:

Do not operate height control valve when:

- Trailer is uncoupled.
- Trailer brakes are applied.

Always leave a parked trailer with the suspension lowered.

The raise/lower valve allows lifting/lowering of the trailer bed by pressurising/depressurising the air suspension bellows.

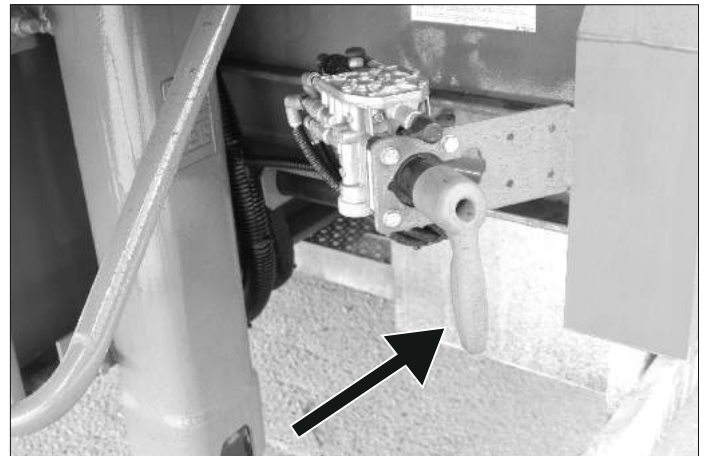

To RAISE or LOWER the suspension

1. Push control lever handle IN.
2. Set control to either RAISE or LOWER position. When trailer floor reaches the required level (or maximum allowable) set the control back to the centre position.

To RESET the suspension to the running (RIDE) height

1. Ensure control is set in central position.
2. Pull lever out to reset suspension.

NOTE: To operate lever, push in and turn to required position as outlined above. Always return lever to central position and pull the lever OUT before driving away.

NOTE: There is a Reset-to-Ride facility incorporated in the raise/lower system. It will 'pop' the button OUT in all instances as a fail safe.

To 'DUMP' the suspension

1. Push the control lever FULLY in. This allows the operator to walk away whilst the suspension dumps.

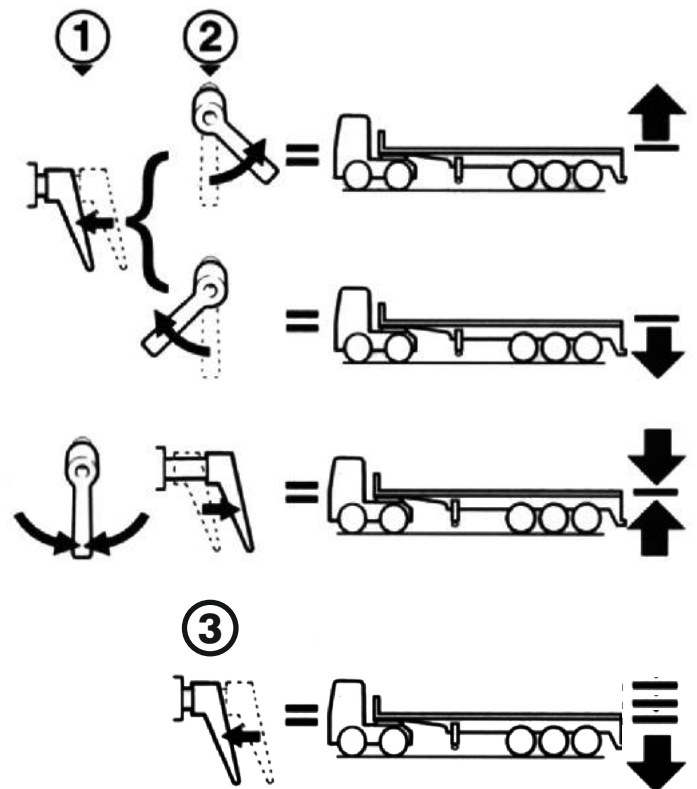

LIFT AXLE

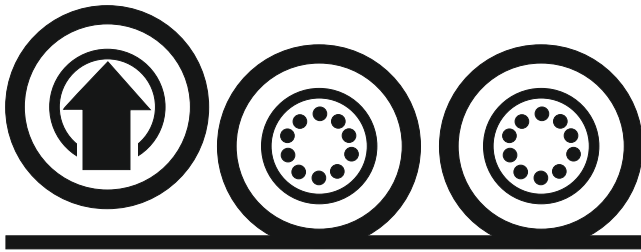

Automatic control feature may be de-activated for MOT and maintenance **ONLY** by disconnecting the ISO 7638 power connector or, if fitted, via an override switch normally located to the left in front of the running gear.

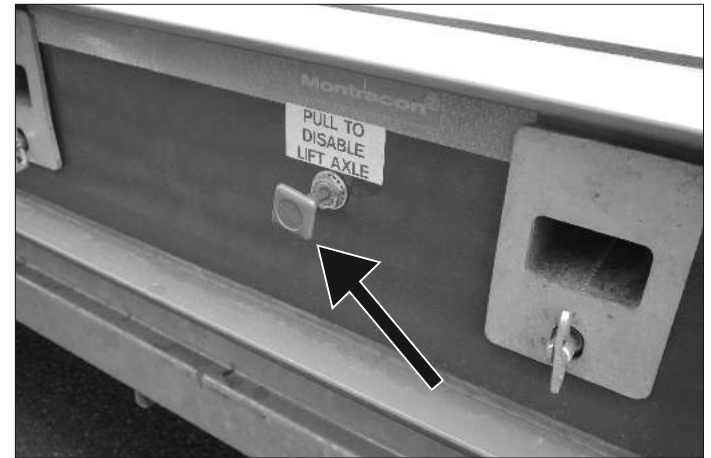

WARNING:

Highway running can only be recommended for a raised axle if a clearance of more than 90mm exists between the tyre and the ground.

Ensure all personnel stand clear of raised axle when loading and unloading.

NOTE: To lift axle, power must be connected from ISO 7638EBS.

The pneumatic lift allows individual axles to be raised off the ground to reduce tyre friction/wear when turning. Use of the system is dependent on the weight of the load on the vehicle.

Fully automatic lift and lower.

Lifting/lowering of the axle or axles is automatically triggered by the load on the trailer. The automatic lift will 'decide' how many axles may be lifted off the ground or returned to the ground (i.e. axles will remain up as long as feasible). Axles will not rise if they are loaded beyond their design limit.

BRAKE SYSTEM

CONTENTS

1. General Information	Page 34
2. Operation	Page 34
3. Essential Maintenance	Page 35
4. Anti-Lock Brake System	Page 37
5. Brake System Information Plate	Page 37
6. Trailer Information Module (Info Centre)	Page 38
7. Standard Park Brake / Brake Release	Page 39
8. Air Loss and Brake Protection	Page 40
9. Brake Actuator Release Procedure	Page 41

This section covers a wide variety of components that are used on Montracon trailers. Not all components will appear on one vehicle, therefore certain instructions contained herein will not apply. Where special instruction beyond the scope of this section is required, this will be supplied as supplementary information.

IF IN DOUBT, ASK!

GENERAL INFORMATION



WARNING:

For safety reasons repairs on brake systems should be limited to qualified and skilled personnel. never try to change the original settings of the brake valves.

Articulated vehicles registered in the UK are required to meet European braking legislation as specified in EU Directive 71/320/EU or UNECE Regulation 13. This requires that brakes on each part of the vehicle combination perform within the compatibility corridor i.e Brake performance plotted against applied pressure for both laden and unladen conditions.

The law requires that regular technical inspection of the brake system is mandatory. Carrying out this inspection is limited to skilled personnel and requires appropriate equipment.

To optimise brake action/performance and lining wear, we recommend that an approved service outlet does the fine-tuning.

Data required for repair and inspection of the brake system is contained on the Load-Sensing Valve Data Plate. (For sample refer to page 4 “Vehicle Identification” or page 38 “Brake System Information Plate”.)

OPERATION

When connecting supply lines between the tractor and trailer FIRST connect “brake” coupling (yellow) and then “emergency” or “storage” coupling (red). Reverse the above procedure for disconnecting.

CAUTION!

If pressure in the air reservoirs drops to below 3 bar (43.5 psi), maybe after operating the park brake valve or the brake release valve several times, or possibly due to a leaking brake circuit, the service brakes will not disengage by applying the park brake.

To release, refill air reservoirs or completely vent brake system with the drain valve located on the air reservoir (make sure the vehicle is secured correctly, with chocks).

ESSENTIAL MAINTENANCE

The following checks should be carried out in addition to those listed in 'Maintenance and Care' Page 46. Drivers and operators have a direct responsibility to complete 'Essential Maintenance' by carrying out the routine below. He/she should report any faults to maintenance personnel.

NOTE: In a working a prime mover may be used with several trailers all of which will require checking before use.

DAILY

Coupling Heads:

Before connecting, inspect seals for wear and damage. Replace where defective. After having connected couplings, check for leaks. Close protective caps on couplings after disconnection.

Drain Air Reservoir Tanks:

The biggest enemy of air brakes is condensation/water in the system. Drain by pulling the drain valve ring at the bottom of the air reservoir.

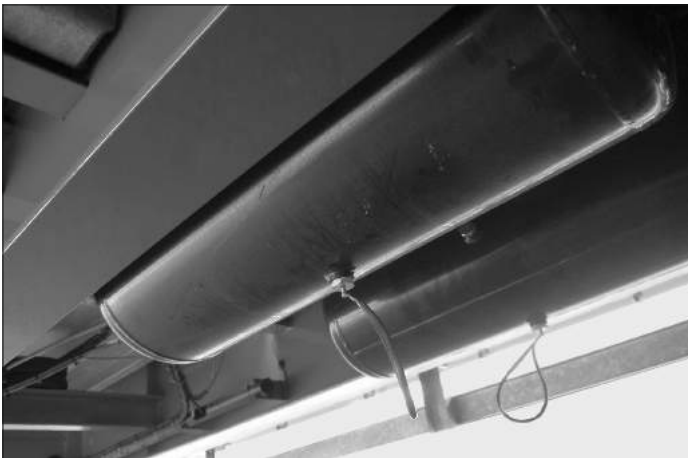

WEEKLY

Brake Adjustment:

Weekly for the first four weeks, then quarterly or every 16,000km / 10,000 miles thereafter.

Drum Brakes:

Check slack adjustor movement, see page 59 and brake lining wear indicator (1).

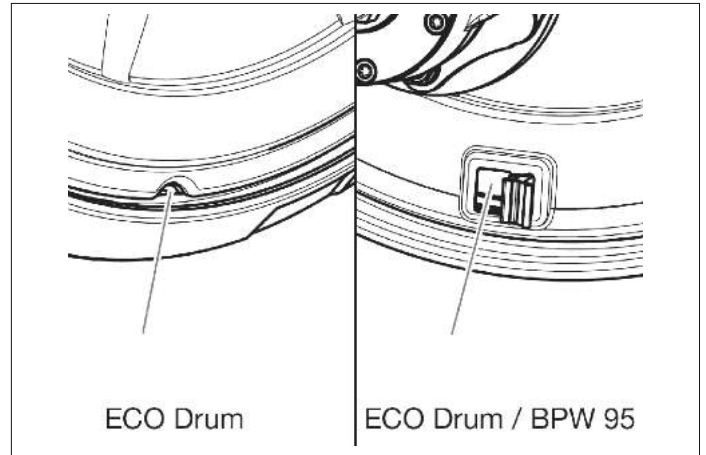

MONTHLY

Inspect pneumatic system for leaks:

Operating pressure must not drop by more than 0.1 bar (1.5 psi) over 10 minutes. If pressure drop exceeds this, report fault to maintenance personnel.

Tip: Use soapy water and a spray bottle to detect air leaks.

ESSENTIAL MAINTENANCE (cont)

QUARTERLY

Clean in-line filter:

Release all air pressure. Remove filter cartridge and clean with compressed air. Replace defective filter right away. Re-assemble ensuring 'O' ring is fitted.

Service brake linkages: (fig 1)

Lubricate service brake cylinder actuator rod linkages and valve pivots.

Brake cylinder: (fig 2)

Check brake cylinder attaching bolts, torque to 180Nm (133lb.ft)
 Check brake cylinders and air lines have firm seat.
 Check actuation.

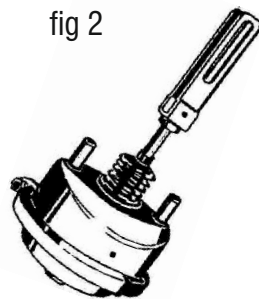
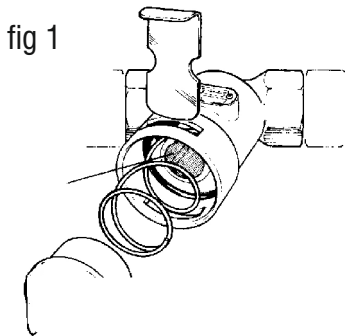

If any of the above brake components are faulty they will affect trailer brake efficiency. Take vehicle to the nearest approved brake service outlet for rectification/replacement immediately.

ANTI-LOCK BRAKE SYSTEM

The anti-lock brake system features an on-board electronic control unit (ECU) with self-diagnostic capabilities. Dedicated power is via the ISO 7638 connector. Alternative (back up) power via either the ISO 1185 (24N) 'Normal' connector or by the 'Supplementary' ISO 3731 (24S) connector. Usually alternative power is coupled via the brake light circuit of the ISO 1185 (24N) 'Normal' connector. The ECU will detect the primary source of supply i.e if all three connectors are coupled the dedicated ISO 7638 line will be seen as the primary source.

Electronic Braking Systems:

Electronic Braking Systems (EBS) also incorporates electronic load-sensing equipment, which is powered via the ISO 7638 connector.

If the tractor unit is fitted with the dedicated ISO 7638 connector there will be a red lamp on its dashboard to display the functioning of the trailer EBS: this lamp is the primary indicator lamp for the trailer EBS.

Anti-Lock Brake System Check:

When turning ignition ON, system will go through a self-test routine.

Two systems are fitted (either A or B). The following light sequence indicate correct operation of the EBS system.

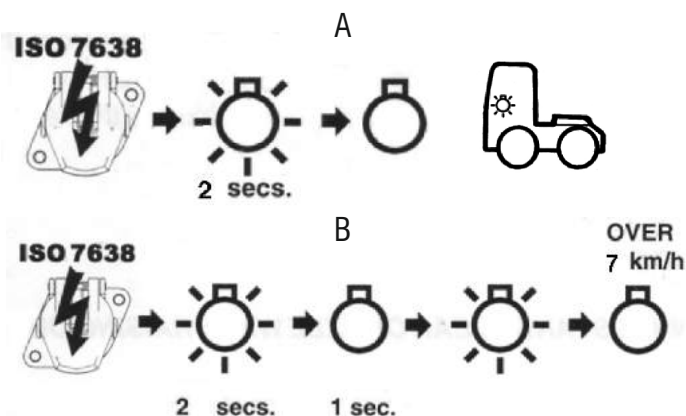

MALFUNCTION:

No light or a continuous light on at initial power-up and/or a continuous light on above 7 km/h indicates a fault. Check fault immediately!

Circuit Testing



WARNING:

Test the EBS system using specially designated diagnostics equipment recommended/supplied by its manufacturer.

If EBS fails (anti-lock with electronic load sensing) the self diagnostic ECU will indicate the fault. Have an approved brake service outlet shop take care of any defect straight away.

BRAKE SYSTEM INFORMATION PLATE

The brake setting table/plate contains valuable information required for inspection and repair of the brake system.

Haldex		EB+ ADR T0.EGG.094-04		2S/2M Stability		EA 212	EA 217mm 904	EA 228				
TRAILER MANUFACTURER / FAHRZEUGHERSTELLER / CONSTRUCTEUR		Montracon		BRAKE CALCULATION NO. / BREMSRECHENUNGSLINIE / CALCULO DE FREMSAET NO.		2010241.1						
CHASSIS NUMBER / FAHRZEUGCHASSISNUMMER / NUMERO DE CHASSIS		121895		TRAILER TYPE / TRAILERTYP		semi-trailer						
SERVICE PRESSURE / SERVICEFEDERDRUCK / PRESSION D'APPRESSION [bar]		0.30		PRESSURE LIMIT / DRUCKGRENZWERTE / LIMITE DE PRESSION [bar]		8.50						
UNLADEN / LEER / A VIDE [1.00 bar = 100 kPa]					LADEN / BELADEN / EN CHARGE [1.00 bar = 100 kPa]							
		INPUT PRESSURE / EINGANGSDRUCK / PRESSION D'ENTREE [bar]		6.30		INPUT PRESSURE / EINGANGSDRUCK / PRESSION D'ENTREE [bar]		0.70 2.00 4.50 6.30				
		ABLE LOAD / ACHSLAST / CHARGE SECUR TR [daN]		SERVICE PRESSURE / SERVICEFEDERDRUCK / PRESSION DE SERVICE [bar]		INPUT PRESSURE / EINGANGSDRUCK / PRESSION D'ENTREE [bar]		OUTPUT PRESSURE / AUSGANGSDRUCK / PRESSION DE SORTIE [bar]				
0	0	0	0	1265	0.40	2.30	8000	4.80	0.50	2.00	4.40	6.30
0	0	0	0	1265	0.40	2.30	8000	4.80	0.50	2.00	4.40	6.30
0	0	0	0	1265	0.40	2.30	8000	4.80	0.50	2.00	4.40	6.30

TRAILER INFORMATION MODULE (AS EQUIPPED)

The diagnostic unit is normally mounted on the side of the main frame. It provides ready access to trailer related information such as mileage, bogie load, trip distance, service interval status, brake wear, brake system diagnostics and fault codes, plus other information.

NOTE: For more details please refer to the unit 'Manufacturer's Instructions'.



STANDARD PARK BRAKE/BRAKE RELEASE

(Other types may be fitted which require different operation at customers request).

Park & Shunt Valve



WARNING:

Do NOT use the trailer brake release valve.

The Park and Shunt Valve is fitted to trailers incorporating spring brake systems and dispenses with the need for a manually operated trailer handbrake.

The park valve and the trailer brake release valve are housed in one unit usually mounted at the UK nearside close to the front support legs.

On disconnection of the emergency (red) line, the brakes are automatically applied. As the air is depleted the spring brake system maintains brake engagement through powerful springs in the brake cylinders.

Trailer brakes can be applied when coupling to the tractor or prior to uncoupling from the tractor by pulling the park valve control button. The valve will require resetting before moving off.

Trailer Shunt Valve



WARNING:

Ensure this valve is reset to its original position after use.

This valve allows the brakes of uncoupled trailers to be released. However, it is not recommended that this valve is used for moving the trailer with vehicles not suitable for the purpose. A trailer should only be moved when coupled to a vehicle with an appropriate air supply.

NOTE: Spring Brakes need sufficient air pressure in the reservoir to compress powerful springs in the actuators (see Park Brake).

Operation of Park Shunt Valve & Trailer Shunt Valve

ATTENTION: Before you can drive push the red button at the parking valve.



Trailer uncoupled

The red button will be pushed out automatically, the spring brakes will come on.

Before you can drive

Connect coupling heads, reservoir pressure must be >5 bar, push the red button to release the spring brakes.

AIR LOSS & BRAKE PROTECTION

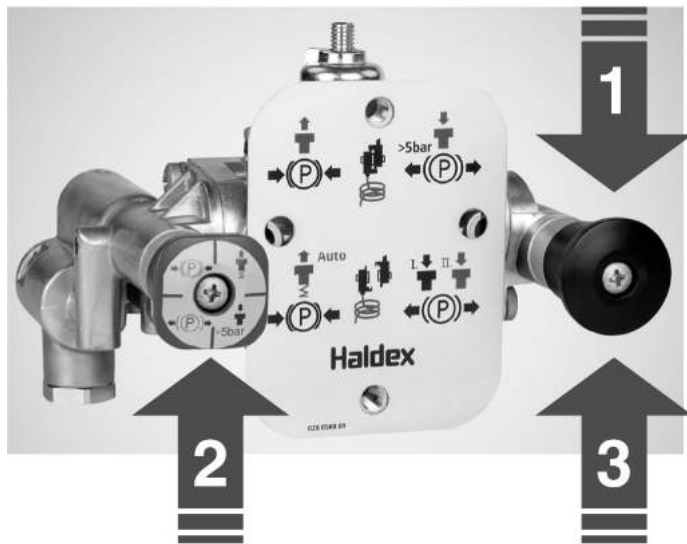

WARNING:

Under no circumstances should the protection valve be tampered with.

If there is a loss of air from the air suspension, the braking system should maintain a constant safe pressure of 6.0bar (87psi) by means of a protection valve in the system, ahead of the air suspension reservoir.

A supply pressure of over 6.0bar is generally required to open this valve and allow air through to the air suspension.

Shunt the trailer w/o the emergency line

1. Push the black button
2. Push the red button to release the spring brakes, you can shunt the trailer.
3. After shunting pull the black button to apply the parking brake.

BRAKE ACTUATOR RELEASE PROCEDURE



WARNING:

CAUTION EXTREME HAZARD!!

Never attempt to open a brake cylinder without having cocked the compression spring first.

In an emergency, e.g. pneumatic failure, brake cylinders may be released mechanically. (Reverse the procedure for spring relief.)

1. Remove re-setting tool from its holder alongside the brake cylinder. This has a threaded pin with bayonet- type lock at one end and a washer with nut on the other.
2. Remove plastic cap on rear end of brake cylinder.
3. Introduce bayonet end of the tool into brake cylinder through orifice.
4. Seize thrust plate with tool and lock bayonet by turning clockwise.
5. Cock brake cylinder compression spring by winding the nut complete with washer on the resetting tool tight (max. torque 70Nm).

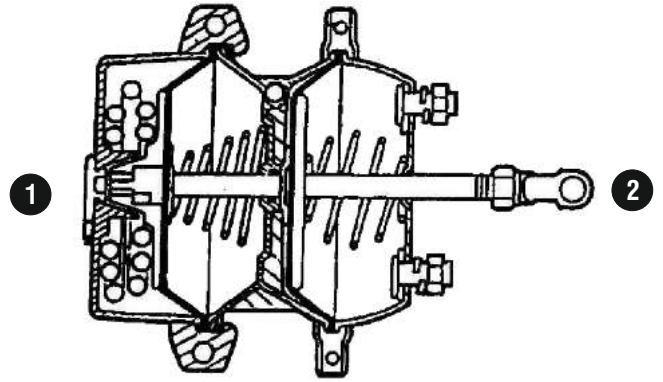

1. SPRING BRAKE END
2. SERVICE BRAKE END

ELECTRICAL SYSTEM

CONTENTS

1. General Information	Page 43
2. Master Fuse	Page 43
3. Standard ISO Lighting, System & Auxillary Equipment	Page 44

This section covers a wide variety of components that are used on Montracon trailers. Not all components will appear on one vehicle, therefore certain instructions contained herein will not apply. Where special instruction beyond the scope of this section is required, this will be supplied as supplementary information.

IF IN DOUBT, ASK!

GENERAL INFORMATION

The electrical system is of the insulated return type, utilising two 7-pin connectors wired in accordance with ISO 1185 and ISO 3731 configuration.

An ISO 7638 connector will be fitted for ABS or EBS dedicated power (see 'Section 4 Braking System').

Compatibility between tractor and trailer electrical connections should always be checked to ensure correct functioning of individual circuits. Just because the plug and socket may easily mate is not an indication of compatibility. Alternative systems may be fitted to customer's requirements. On occasions additional connectors may be fitted for auxiliary equipment, e.g. inspection lamps, removable lighting panel and winches, or to control independent circuits like tail lifts, internal lifts/decks and rear loading ramps.

Electrical Equipment

Outline markers and internal lighting are connected with rear light terminals in the junction box. Normally the switch for the internal lighting is located on the left, at the rear chassis cross-member.

Wiring of outline markers and internal lighting is routed from the junction box through ducting and Bundy tubing via the front/rear & roof.

Wiring of components diagram, see appendix 1 at the end of this document.

To ensure the serviceability of equipment, check that:

- a) The electrical connector(s) are correctly located and secure.
- b) The wiring is properly insulated and secured.
- c) All lights, reflectors and marker boards are secure, clean and functioning.
- d) Damaged lens, bulbs, reflectors etc. are replaced.
- e) When ABS is fitted, the anti-lock warning lamp is functioning correctly.

MASTER FUSE

The power pack and winch (if fitted) circuit(s) are protected by a 200 amp Master Fuse which is located on near-side front neck area.



TYPE: 0-376-20
 SIZE: 200 amp
 COLOUR: Blue
 PART NO: 52030512

ISO LIGHTING SYSTEM AND AUXILLARY EQUIPMENT

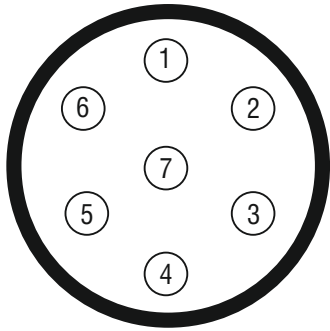

ISO 1185 - 24N
(NORMAL CONNECTOR)

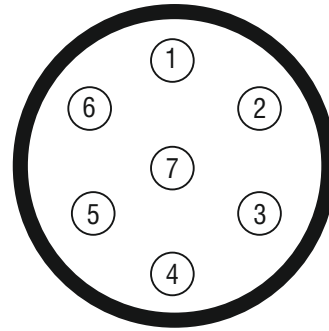

ISO 3731 - 24S
(SUPPLEMENTARY CONNECTOR)

ISO 1185 - 24N

Pin No./ Terminal	Function	Colour Code
1	Common Return	White
2	Front, Side, Rear, No Plt Lamp & Tail (LH)	Black
3	Directional Flasher (LH)	Yellow
4	Stop Lights	Red
5	Directional Flasher (RH)	Green
6	Front, Side, Rear, No Plt Lamp & Tail (RH)	Brown
7	Spare	Blue

ISO 3731 - 24S

Pin No./ Terminal	Function	Colour Code
1	Common Return	White
2	Spare	Black
3	Reverse	Yellow
4	Spare/Switch Cab op.	Red
5	Spare/Switch Cab op.	Green
6	Spare/Switch Cab op.	Brown
7	Rear Fog Light	Blue

NOTE: ISO 1185 Pins 2 and 6 can be linked to make the arrangement compatible with early tractor units utilising a single 7 pin system. Also, pin 4 (24N) may include wiring to provide supplementary power for trailer anti-lock brake system.

ISO LIGHTING SYSTEM AND AUXILLARY EQUIPMENT

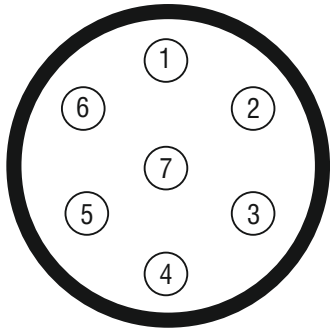

ISO 7638 (7 PIN)
(NORMAL CONNECTOR)

ISO 7638 (7 PIN)

Pin No./ Terminal	Function	Colour Code
1	24 V + VE	Red
2	24 V + VE IGN	Black
3	Ground	Yellow
4	Ground	Brown
5	Warning Lamp	White
6	Can 20	Green
7	Can 763F Free Plug	Brown

NOTE: An ISO 7638 socket is used for the EBS equipment; this is a dedicated 7 pin socket. No additional supply through the ISO 3731 socket is provided.

TRAILER MAINTENANCE & CARE

CONTENTS

1. Readers Guide - Preventative Maintenance	Page 47
2. Torque Values	Page 48
3. Essential Maintenance Schedule	Page 49
4. Recommended Preventative Maintenance Schedule	Page 50
5. Care of Chrome	Page 52
6. Neck Ramp Maintenance	Page 53
7. Rear Ramp Maintenance	Page 54
8. Wheel Jacking	Page 55
9. Wheel Changing	Page 56
10. Care & Maintenance of Trailer Tyres	Page 57
11. Tyre Problems	Page 58
12. Suspension: Checks & Torque Figures	Page 59
13. BPW Automatic Slack Adjustor - Operation Check	Page 60

This section covers a wide variety of components that are used on Montracon trailers. Not all components will appear on one vehicle, therefore certain instructions contained herein will not apply. Where special instruction beyond the scope of this section is required, this will be supplied as supplementary information.

IF IN DOUBT, ASK!

READERS' GUIDE - PREVENTATIVE MAINTENANCE

IMPORTANT: It is the trailer owners responsibility to ensure maintenance is carried out at regular intervals by competent personnel!

A conscientious driver has a direct contribution to make regarding preventive maintenance, through their ability to recognise faults and inform maintenance personnel accordingly.

To assist with this, a list of checks is included in this section.

It should be remembered that one prime mover could be coupled to several semi-trailers in the course of a working day and that each trailer should therefore be checked before use.

The remainder of this section contains sufficient technical information to cover maintenance during the first four weeks of trailer operation, followed by preventative maintenance charts to assist workshop staff with future planned servicing.

IMPORTANT: Before carrying out any maintenance it is important the operator understands the need to wear correct safety clothing and the need to use relevant safety equipment.

Do not wear loose fitting clothing. Extra safety equipment including hard hat, safety shoes, ear, eye or face protection, heavy gloves and reflective clothing may be necessary. Failure to follow these guidelines could result in personal injury.

IMPORTANT: This handbook does NOT cover detailed assembly/disassembly of components. For further information please refer to the specific manufacturer's maintenance manual.

TORQUE VALUES

Material grade 8.8, thread lubricated.

Thread, metric	Width Across Flats	Torque*
M8	13mm	21 to 26 Nm
M10	17mm	42 to 51 Nm
M12	19mm	72 to 89 Nm
M14	22mm	114 to 141 Nm
M16	24mm	174 to 215 Nm
M18	27mm	240 to 295 Nm
M20	30mm	340 to 420 Nm
M22	32mm	455 to 570 Nm
M24	36mm	580 to 725 Nm
M30	46mm	1160 to 1450 Nm
M36	55mm	2030 to 2530 Nm

*The above torque figures are for standard nuts; reduced values by 50% when using flat-head screws.

- Refer to different torque values specified for individual component groups in this handbook.
- Check axle manufacturer's manual for wheel nut torque values.
- Replace self-locking nuts after having unthreaded twice.

ESSENTIAL MAINTENANCE (First 4 weeks of operation)

During the first 4 weeks of operation the following maintenance tasks (shown in the diagram below) should

be carried out over and above your Company's own procedures for Daily checks, Service and Maintenance.

Operation	Initially	Daily (for first 4 weeks)	Weekly (for first 4 weeks)	First Month
Torque:				
Wheel Nuts	After First Journey	✓		
Suspension Nuts/Bolts*			✓	
King Pin Bolts			✓	
Body Bolts				✓
Check:				
Tyre Pressures	Prior to First Journey	✓		
Air Leaks	Prior to First Journey	✓		
Correct Function of Lights	Prior to First Journey	✓		
Brake Hoses	Prior to First Journey	✓		
Brake Adjustment			✓	
Hub Bearings			✓	
Shock Absorbers			✓	
Hydraulic Power Pack Oil Tank Level		✓		
Grease:				
Cam Shaft Bearings				✓
Drain:				
Air Tanks**		✓		

*Refer to 'Suspension: Checks and Torque Figures' on page 59

**Refer to 'Braking System Essential Maintenance on Page 35'.

RECOMMENDED PREVENTATIVE MAINTENANCE SCHEDULE

A. Daily Inspection

B. Weekly

C. Monthly

D. 3 x Monthly

E. 6 x Monthly

F. Annually

	A	B	C	D	E	F
Check lights, reflectors, wiring and lenses are not damaged. Replace as necessary	✓					
Check condition of flooring	✓					
Check hydraulic system for leaks and pipe damage	✓					
Check operation of neck and rear ramps, taking particular attention for any leaks	✓					
Check hydraulic power pack oil tank level		✓	✓	✓	✓	✓
Remove all loose objects from body	✓					
Check condition of lashing rings	✓					
Check brakes for correct functionality	✓	✓	✓	✓	✓	✓
Check lining/pads for wear and adjust if required				✓	✓	✓
Overhaul brakes (lubricate anchor pins etc. If necessary finish* the brake lining/drum surfaces)						✓
Inspect brake hoses for damage		✓	✓	✓		
Drain air reservoir (daily in freezing conditions)		✓	✓	✓	✓	✓
Check camshaft bearings & lubricate		✓	✓	✓		
Grease-slack adjuster		✓	✓	✓		
Test anti-lock brake system		✓	✓	✓		
Check all brake system valves for correct operation		✓	✓	✓		
Test emergency valve (incorp. Park & Shunt)		✓				
Overhaul actuators, emergency & quick release valves		✓				
Inspect tyres for damage		✓	✓	✓	✓	✓
Check tyre pressures		✓	✓	✓	✓	✓
Torque load wheel nuts		✓	✓	✓	✓	✓
Check hub bearing adjustment**		✓	✓			
Clean out hubs, bearings** and re-pack with fresh grease		✓				
Torque load axle and suspension nuts***		✓	✓	✓		
Inspect axle & suspension components for wear & damage		✓	✓	✓		
Check axle alignment		✓	✓			
Check air suspension system for leaks		✓	✓	✓		
Clean in-line air filter		✓	✓	✓		

RECOMMENDED PREVENTATIVE MAINTENANCE SCHEDULE (cont)

	A	B	C	D	E	F
Inspect neck ramp pivot points & locking pins		✓	✓	✓	✓	✓
Grease / oil rear ramp pivot points		✓	✓	✓	✓	✓
Grease neck ramp support pins		✓	✓	✓	✓	✓
Grease manual levers for hydraulic valve block operation			✓			
Check ride height		✓	✓	✓		
Check lift axle components (if fitted)		✓	✓	✓		
Check condition of chrome to hydraulic cylinders		✓	✓	✓		
Check condition of winch wander lead & radio remote control		✓	✓			
Check condition and operation of winch according to manufacturers instruction		✓	✓	✓		
Check electrical system for correct functionality		✓	✓	✓	✓	✓
Inspect electrical cables for damage & security		✓	✓			
Inspect ancillary equipment for security		✓	✓	✓		
Grease, inspect & check for security: Support legs		✓	✓			
Fifth wheel		✓	✓	✓	✓	
Rubbing plate & king pin		✓	✓	✓	✓	
Inspect for security & corrosion: Steelwork & finished surfaces		✓	✓			
Check identification plates		✓	✓	✓	✓	✓
Winch (as applicable). Periodically check tightness of the mounting bolts and electrical connections. Remove all dirt and corrosion and always keep clean.	✓	✓	✓	✓	✓	✓

*Linish is a pattern of very fine lines achieved by abrading the surface with by hand using suitable paper on the brake linings and emery cloth on the drum. The pattern should be in two directions each at 45 degrees across the surface to give a cross hatched effect. Do not use hand or power tools.

** Refer to manufacturers manual

*** For all torques and other information please refer to 'Suspension: Checks & Torque Figures' on page 59.

CARE OF CHROME

The care of the chrome rod on the hydraulic cylinders is essential in maximising their service life.

All hydraulic cylinders with chrome exposed to the elements must be greased to protect against corrosion, both during service and when in storage or periods of non-operation.

The Chrome rods can become damaged from normal use and/or through routine servicing and repair of the trailer ie. from stones, road grime, road salt, welding and grinding.

It is therefore recommended that Nitric Solvent (without chlorate) is used on exposed Chrome rods to clean any dirt and water regularly.

After cleaning it is recommended a spray grease is applied on any exposed Chrome rods.

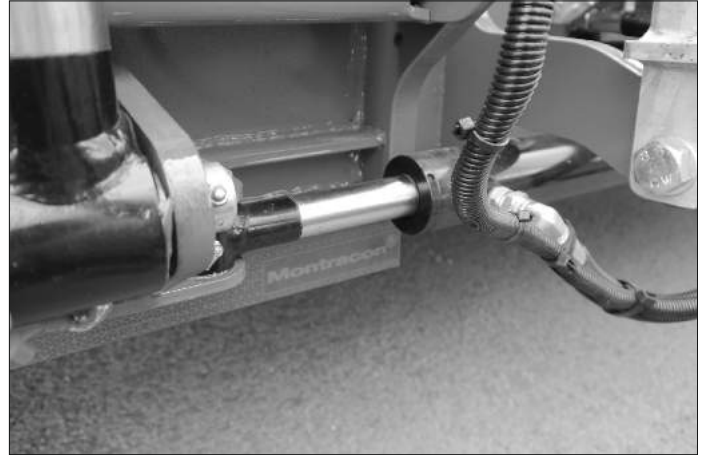

NECK RAMP MAINTENANCE

Daily Checks

1. Regularly check that there are no foreign objects caught in the hinge area.
2. Check the function of the ramp by operating the unit into the raised and into the flat position.
3. Check for any damage to the ramp.
4. The ramp is lifted via an airbag, so a visual check of the bag is required to see if there are any leaks or damage.
5. The retractable support pins slide in a housing, these need to be lightly greased during routine maintenance & given a visual inspection.

NOTE: Copper grease is recommended as it does not attract dirt like normal grease.

6. The air chamber that extends and retracts the pin requires a visual inspection to check for any damage.

IMPORTANT: Replace any worn or broken parts (as soon as a fault is identified).

Weekly Checks

1. Look for any wear and tear in the pivot points and locking pins.
2. The ramp pivot point is a full width bar which sits loosely in a box section housing on the chassis & ramp so a visual inspection is required.

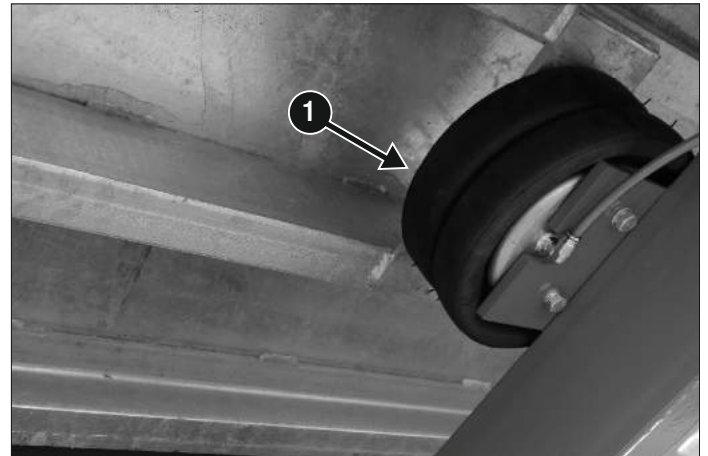

1. RAMP AIR BAG

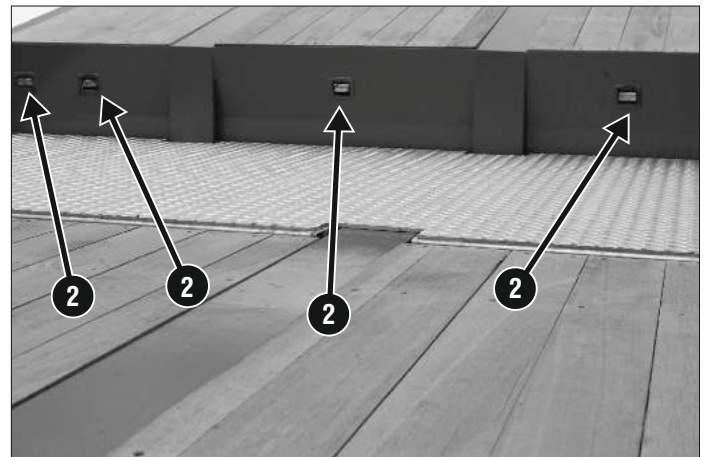

2. RETRACTABLE SUPPORT PINS

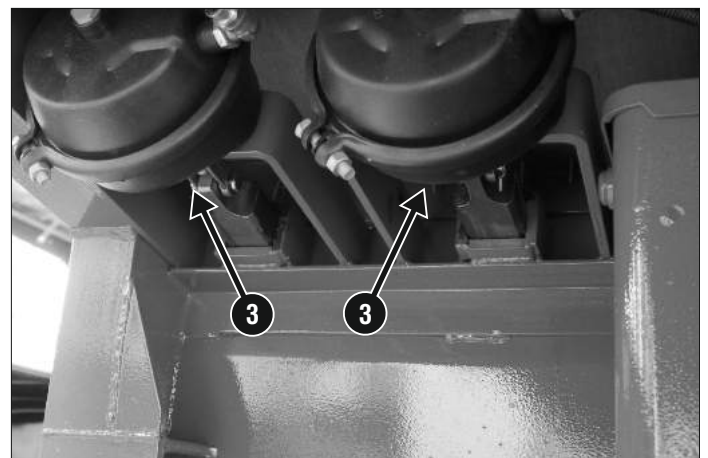

3. SUPPORT PIN AIR CHAMBERS
(2 x N/S, 2 x O/S, + 1 x Centre)

REAR RAMP MAINTENANCE

Daily Checks

1. Check the functionality of the rear ramps by lowering and then raising. Check the flip toe-ends (if fitted) unfold correctly.
2. Check the side-shift functionality (if fitted) and no foreign objects are caught restricting side movement.
3. Check for any damage to the ramps.

IMPORTANT: Replace any worn or broken parts (as soon as a fault is identified).

Weekly Checks

Grease/oil all ramp pivot points (as applicable).



Both sides - (O/S cylinder shown)

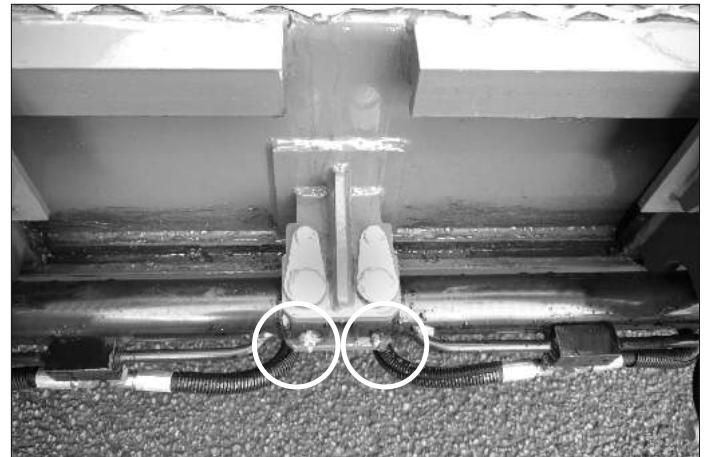

2 x Pivot Points - Central

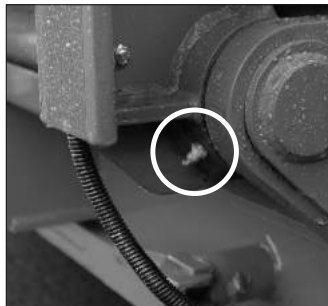

Both sides - (O/S ramp shown)

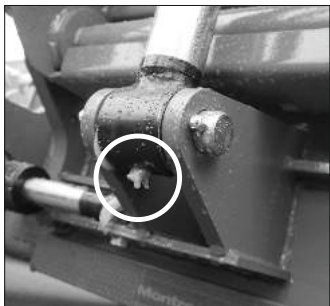

Both sides - (O/S cylinder shown)



Both Sides - (O/S Locking Pin Shown)

WHEEL JACKING

All jacking operations must be carried out on firm level ground with the parking brake applied. The vehicle must be securely chocked at the wheels (on opposite sides) and suitable blocks placed under the axle for additional safety.

Most suspensions allow for jacking under the inside of the axle chair, near to the spring or trailing arm or at the centre of the axle. A typical example is illustrated below.

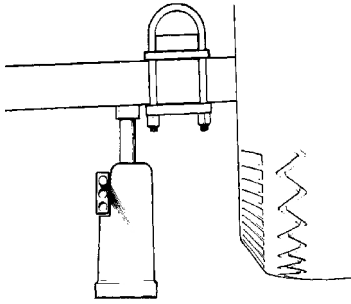

IMPORTANT: To prevent slipping ensure the jack head is suitably shaped to accept the profile of the axle.

Where it is not possible to jack in the position previously described, jacking must only be carried out with consideration to following:

- Do not jack under castings.
- Do not jack under springs or air suspension trailing arms.
- Do not jack under hanger brackets.
- Do not jack under the rear under-run bump bar.
- Do not jack under chassis/sub frame forward of the suspension.

Jack under the 'I' beams behind the suspension, only where stiffeners are provided between top and bottom flanges. Spread the loads along the beam as much of as possible by using timber packing between the jack and frame. Timber packing should be in excess of 75mm thick and should extend longitudinally at least 200mm either side of the jack position.

WHEEL CHANGING

ISO Spigot Wheels

ISO spigot mounting is where the wheel is centralised to the hub on a protruding lip (spigot) and secured by ISO nuts with captive collars. The wheel nave will usually feature parallel fixing holes. However, wheels with conical or spherical faced holes can be used on spigot hubs, providing the wheel has never been used on alternative types of mounting.

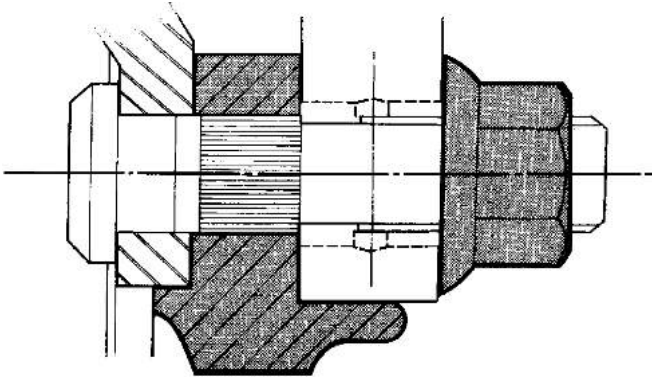

NOTE: Protective wheel nut covers and loose nut indicators may be fitted. Replace on completion.

1. To remove a road wheel, slacken the wheel nuts and jack up adjacent to the respective wheel(s) as previously described.
2. Remove wheels nuts and wheel(s).
3. To fit a wheel, lightly lubricate the thread of the wheel nuts and check the captive collar on ISO spigot nuts, rotate freely.
4. Position the wheel to be fitted as near as possible to the hub, place a bar underneath the base of the tyre and lever the wheel upwards and over the studs, taking care not to damage the threads. Repeat this operation for the second wheel where necessary.

5. Re-fit wheel nuts and tighten by hand.

6. Tighten in sequence by spanner. Remove jack and finally torque load the nuts in sequence, (torque to 600 Nm) repeating after the first 80km (50 miles) and daily for the first week. Replace protective wheel nut covers and loose nut indicators (if applicable).

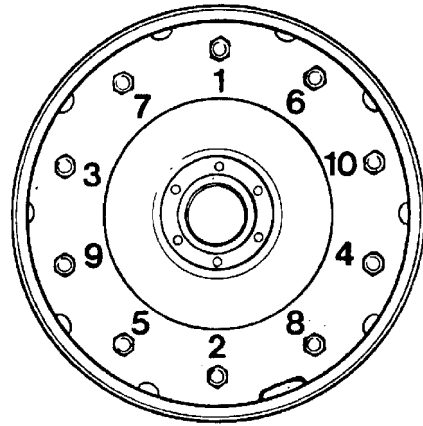

7. Torque all wheel nuts WEEKLY. (torque to 600 Nm). It is recommended that all the wheel stud holes are checked periodically for ovality as an early indication of wheel problems. Over-tightening of wheel nuts will cause the hole to distort radially, while fretting as a result of under tightening causes circumferential distortion.

NOTE: Mating surfaces between wheels and hubs, and wheels and wheel nuts, should not be painted.

Non-Spigot Mounted Wheels

Wheels not mounted to ISO spigot hubs will require the installation of cones. Check correct installation before fitting wheel. The wheel needs centralising on the studs by leverage whilst tightening. **If in doubt ask!**

CARE & MAINTENANCE OF TRAILER TYRES

Tyre Pressures



WARNING:

Failure to maintain tyres at recommended pressures can cause premature tyre wear/failure and poor fuel economy. Eg. Running with high tyre pressures on low laden weight trailers can cause flattening of tread centres.

It is important that operators determine the required tyre pressures for the imposed axle loads. Tyre pressure figures will differ by up to 0.5bar, dependent on axle load.

Operators continuously running vehicles with low laden (axle) weights should reduce the pressures in the trailer tyres accordingly, and vice versa.

Refer to tyre manufacturer's technical information.

Drivers and maintenance staff share the responsibility of ensuring tyres are operated within the bounds of safety and efficiency.

The following checks are recommended for maximum tyre life:

Pre-journey checks by driver and/or maintenance staff

1. Obvious signs of under inflation.
2. State of wear on crown and shoulders.
3. Cuts in tread or sidewalls.
4. Bulges in sidewalls.
5. Remove stones/foreign objects trapped in tread.
6. Remove objects trapped between tyres in twin combinations.

Periodic checks by maintenance staff

1. Correct inflation pressures.
2. Leakages at valves.
3. Missing valve caps.
4. Remaining tread depth, state of wear and correct alignment.
5. Valve accessibility (twin wheels correctly positioned so that inner valves can be reached, provision of correct extension where required).

TYRE PROBLEMS

Symptoms	Causes	End Result / Failure
Uneven tread wear	Under inflation	Fire risk, fracture or rupture of cords
Excessive heat build up		
Wear concentrated on centre of tread	Over inflation or worn shock absorbers	More susceptible to damage Fracture of cords
Spotty tread wear	Grabbing brakes. Slack, worn or broken wheels bearings. Oval brake drums	Reduction to tyre cords
Scrubbing		
Tread cuts	Stone, gravel sharp metal debris etc	Damage to tyre cords
Irregular wear on shoulder of tyre	Overloading	Bursting
Rapid wear	Excessive deflection due to mismatching* of tyres	Premature failure

Tyres should be properly matched for diameter. If the tread depth between the tyres varies the tyres are mismatched. The difference should not exceed 5mm for twin wheel combinations and 10mm when pairing part worn tyres with new and/or re-grooved tyres.

Wheel / tyre assemblies are supplied with the tyre pressures set at 125 psi (8.75 bar) as standard, to suit maximum permissible axle loadings. Operators may reduce the tyre pressures to suit operational axle loadings if required.

ALWAYS refer to the tyre manufacturer’s technical information for clarification.

SUSPENSION: CHECKS AND TORQUE FIGURES

IMPORTANT: For service intervals and maintenance/checks procedures refer to the relevant manufacturer's suspension manual.

SL - TIGHTENING TORQUES

100MM WIDE SPRING M30 pivot assembly

****Shock absorber fixing (Upper) M 24***
Steel hanger M = 420 Nm
Alu hanger M = 320 Nm
(lubricated thread).

****Shock absorber fixing (Lower) M24***
M = 420 Nm
(lubricated thread).

****Air bag fixing M12 (Upper) M = 66 Nm**

NOTE:

Positions marked * must be tightened with the suspension set at the correct ride height. Use a general purpose grease to lubricate the threads where stated.

**** Pivot Bolt assembly - M30***
Steel/Alu hanger M = 900 Nm
'C' channel M = 900 Nm
(lubricated thread).

**** IN ALL CASES TORQUE TIGHTEN INITIALLY AFTER FIRST 2 WEEKS OF OPERATION AND THEN ANNUALLY.**

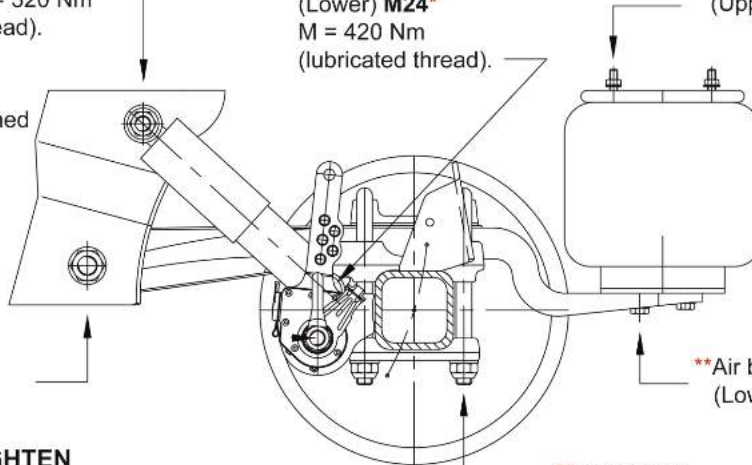

****U-Bolt M24**
M = 650 Nm
(lubricated thread).

****Air bag fixing M16 (Lower) M = 230 Nm**

AL-HD - TIGHTENING TORQUES 70MM WIDE SPRING / M24 U-BOLTS WELDED CLAMPING

****Shock absorber fixing (Upper) M 24***
Steel hanger M = 420 Nm
Alu hanger M = 320 Nm
(lubricated thread).

****Shock absorber fixing (Lower) M24***
M = 420 Nm
(lubricated thread).

****Air bag fixing M12 (Upper) M = 66 Nm**

****U-Bolt M24**
M = 650 Nm
(lubricated thread).

Pivot Bolt assembly - M24*
Geomet coated
Steel/Alu hanger M = 650 Nm
'C' Channel M = 650 Nm

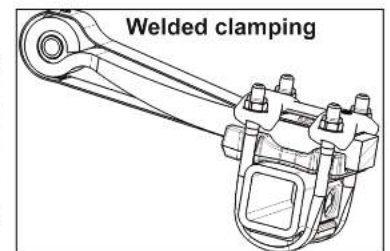

****Air bag fixing M16 (Lower) M = 230 Nm**

**** IN ALL CASES TORQUE TIGHTEN INITIALLY AFTER FIRST 2 WEEKS OF OPERATION AND THEN ANNUALLY.**

BPW AUTOMATIC SLACK ADJUSTER - OPERATION CHECK (Every 6 months)

Make sure the vehicle is made safe to prevent rolling away as the brakes will need to be released for the check to be carried out.

Remove rubber seal cap. Turn back adjustment screw by approximately 3/4 of a turn in a clockwise direction using a ring spanner. A play of at least 50mm with a lever length of 150mm must be available. Actuate the brake lever several times by hand. When this is done, automatic adjustment must take place smoothly. Engagement of the clutch coupling is audible and on the return stroke the adjustment screw turns slightly in a clockwise direction. Grease with BPW ECO-Li Plus.

PLEASE NOTE: Artwork is for illustration purposes only and may not reflect the brake configuration fitted to your trailer.

Set the freeplay by disengaging the clutch on the slack adjuster and turning clockwise until brake bind is achieved, proceed to turn 180 degrees anti-clockwise to achieve between 0.7 - 1.0mm lining to drum clearance. Position the brake lining indicator in the vertical position and tighten the camshaft nut to 60 - 70 Nm.

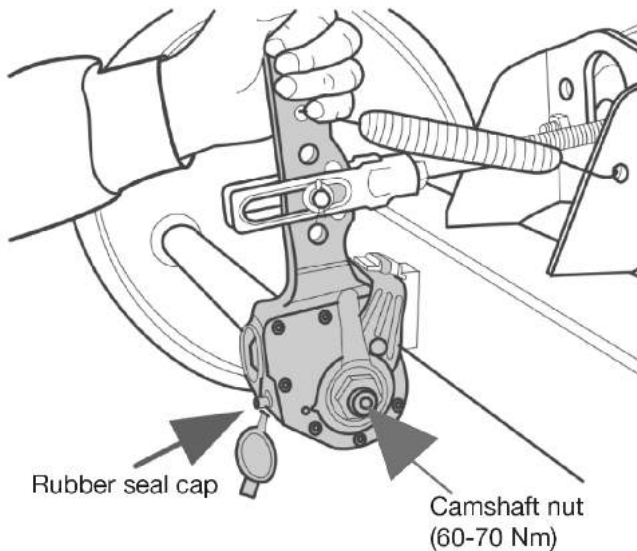

APPEARANCE MAINTENANCE

Vehicle Cleaning Systems

Aluminium is used in the manufacture of many trailers. It is susceptible to corrosive attack from the alkaline cleaning solutions generally used. It is therefore recommended that aluminium components/parts are NOT cleaned with these solutions.

If you cannot avoid using cleaning solutions then the following may provide assistance:

Ensure that the pH of the cleaning fluid and water solution is not greater than 10.5

Ensure that after vehicle cleaning with the solution all components are given a thorough water rinse.

Caution: This will be necessary even if 'drive through' cleaning and rinsing arches are used. The need to thoroughly remove the solution by rinsing cannot be overstressed. Even at a pH of 10.5 corrosive attack will occur.

Hot pressure cleaners can be used, but care should be exercised to keep the temperature below 50°C. The lance should not be used closer than 450mm (18") from the surface.

Paintwork

Paintwork must be maintained at all times, especially in the winter months when the roads are salted.

For obvious reasons care should be taken, especially with areas prone to excess exposure to road grit and salt attack.

Damage to paintwork can occur on areas prone to loading damage and is, therefore, NOT covered under warranty.

To keep the paintwork in good condition, general road film and atmospheric pollution must not be allowed to accumulate. It should be removed at the earliest practical opportunity. Removal of road film can usually be achieved with aqueous detergents. Tar deposits may have to be softened first with P273-901 (BodyKleen) or a Detergent similar to this.

FAULT FINDING

CONTENTS

1. Brakes	Page 63
2. Running Gear	Page 64
3. Air Suspension	Page 68
4. Landing Legs	Page 70
5. Electrical System	Page 70
6. Hydraulic System	Page 71
7. Paint Finish	Page 72

This section covers a wide variety of components that are used on Montracon trailers. Not all components will appear on one vehicle, therefore certain instructions contained herein will not apply. Where special instruction beyond the scope of this section is required, this will be supplied as supplementary information.

IF IN DOUBT, ASK!

Use this section to assist in the diagnosis and rectification of common faults. For more serious problems outside the scope of this information, contact Montracon Customer Service Department on 01302 732500.

BRAKES

Brakes will not release

Probable Cause	Remedy
Park valve set for parking	Reset park valve or handbrake applied release handbrake
Insufficient air supply	Check emergency line (red) is connected and tractor is supplying sufficient air Check for restricted or damaged pipework Check for leaks from valves or pipework, replace as required Open reservoir drain valve to eject any water
Faulty or frozen valve(s)	Check system for correct pressures at test points and check valves for correct function, replace or allow to defrost as required. Do not use methanol or other substances which may be corrosive

Grabbing brakes

Probable Cause	Remedy
Brakes out of adjustment	Re-adjust brakes. If automatic slack adjuster fitted, check for correct operation and rectify if required
Brakes not releasing fully	Lubricate camshaft bushes
Tractor unit	Check pre-dominance from tractor unit

Uneven braking

Probable Cause	Remedy
Contaminated brake linings	Replace brake shoes, check for cause (e.g. worn seal) and rectify
Brakes out of adjustment	Re-adjust brakes. If an automatic slack adjuster is fitted, check for correct operation and rectify if required
Incorrect actuation geometry	Check pre-dominance from tractor unit
Brakes not releasing fully	Lubricate camshaft bushes Strip down brake assemblies, check components, replace as necessary required and lubricate
Check actuator for correct function and leaks	Rectify if required
ABS / EBS fault	Contact ABS / EBS manufacturer

Brakes dragging

Probable Cause	Remedy
Brakes out of adjustment	Re-adjust brakes. If an automatic slack adjuster is fitted, check for correct operation and rectify if required
Brakes not releasing fully	Lubricate camshaft bushes Strip down brake assemblies, check components, replace as necessary required and lubricate
Oval brake drum	Ovality should not exceed 0.12mm (0.005")
Obstruction / insufficient air	Check valves for dirt and operation check for damaged pipework

Inefficient brakes

Probable Cause	Remedy
Brakes out of adjustment	Re-adjust brakes. If an automatic slack adjuster is fitted, check for correct operation and rectify if required
Brakes require overhaul	Strip down brake assemblies, check components, replace as required and lubricate
Non-standard replacement brake linings fitted	Fit new exchange shoes
Low brake (service) line pressure	Check for leaks in service line and at valves with brakes applied; replace as required Check tractor system, i.e. brake valves and pre-dominance

Slow brake application

Probable Cause	Remedy
Brakes out of adjustment	Re-adjust brakes. If an automatic slack adjuster is fitted, check for correct operation and rectify if required
Leak in system when brakes applied	Check for leaks in service line at and at valves with brakes applied; replace as required
Brakes require overhaul	Strip down brake assemblies, check components, replace as required and lubricate

Anti-lock system fault

Probable Cause	Remedy
Continuous ABS / EBS warning lamp above 10kph (6mph)	Check TIM / info centre (if fitted) for active faults. Contact manufacturer or Montracon customer services
No ABS / EBS warning lamp	Check bulb and connections. Contact manufacturer customer services if fault persists
Wheel sensor faults	Remove and clean sensors. Check voltage readings
No voltage to ECU	Check voltage readings at ISO 7638 Check voltage readings at ISO 1185 (24N) connector

Excessive water in air reservoirs

Probable Cause	Remedy
Reservoirs not drained often enough	Drain once a week or daily during freezing weather
Tractor air dryer faulty	Check drier and rectify

Excessive oil in the air system

Probable Cause	Remedy
Tractor compressor faulty	Service compressor; check seals

RUNNING GEAR

Uneven tyre wear

Refer to Hard pulling 'crabbing', below, and also 'Care & Maintenance of Tyres' (page 57).

Hard pulling 'crabbing'

Probable Cause	Remedy
Axle(s) out of alignment	Re-align axles, check all suspension / axle components for damaged U bolts, pivot, pins / bushes, shock absorbers etc and replace as required. Torque tighten all fixings
Broken road spring / trailing arm	Replace
Air suspension down one side	Refer to 'Air suspension faults' on next page

Lift axle will not lift

NOTE: When the trailer is loaded the lift axle will not lift if the axle weights are exceeded.

Probable Cause	Remedy
System not enabled	Check the lift disable valve - push in to enable the lift system.
Insufficient air supply	Build tractor unit air pressure up to 6.0 bar
Leak in system	Inspect for damage, leaks and rectify
Faulty control valve	Check for dirt etc, clean or replace
Electrical fault	Check wiring (check EBS diagnosis if fitted)

Lift axle will not lower

Probable Cause	Remedy
Faulty control valve	Check for dirt etc, clean or replace

AIR SUSPENSION

Air bags flat

Probable Cause	Remedy
Insufficient air supply	Build tractor unit air pressure up to 6.5 bar
Pressure protection / charging valve faulty	Should be set to supply 6.0 bar. Reset or replace valve
Clogged in-line filter	Clean or replace element
Leak in air lines, connections or air bag assembly	Inspect for damage and test for leaks, locate and repair or replace
Faulty levelling valve	Inspect, test and replace, as required
Faulty air load sensing valve	Inspect, test and replace, as required
Faulty exhaust valve (if fitted)	Inspect, test and replace, as required
Faulty raise / lower valve (if fitted)	Inspect, test and replace, as required

Suspension deflates rapidly when parked

Probable Cause	Remedy
Leak in air lines, connections or air bag assembly	Inspect for damage and connections or air bag test for leaks, repair or replace

Excessively worn air bags

Probable Cause	Remedy
Bag contacting the frame, tyres or rim	Check for correct tyre size and inflation. Measure clearances contact Montracon customer services
Over extension of air bags	Adjust 'ride height' Check variable height (raise / lower) valve and set to 'ride' position
Operating with insufficient air pressure	Check items listed under 'air bags flat'
Worn shock absorbers	Replace

Trailer rides too high or too low

Probable Cause	Remedy
Levelling valve linkage disconnected or broken	Repair or replace
Incorrectly set levelling valve	Adjust 'ride height' (see page 30)
Incorrectly set variable height (raise / lower) valve, if fitted	Set to 'ride' position (see page 30)

Excessive shock absorber wear

Probable Cause	Remedy
Faulty levelling valve	Replace valve
Trailer running on bump stops	Reset variable height (raise / lower) valve, if fitted Check items listed under 'air bags flat'
Off-road usage	Take extra care Use trailers on highways only

LANDING LEGS

Difficult to operate

Probable Cause	Remedy
Leg set in high gear	Push shaft in for low gear, if it cannot be selected strip down gearbox and repair / lubricate as required
Lack of lubrication	Remove top covers of leg, clean out old grease, inspect and overhaul if necessary. Lubricate on re-assembly
Bent leg	Replace leg
Gears or components damaged	Overhaul leg

ELECTRICAL SYSTEM

Any electrical fault

Probable Cause	Remedy
Poor connection or broken wire	Check: wiring, junction boxes, connections Ensure continuity, check the insulated earth return. Replace as required

Ramps fail to operate (see also Hydraulic System Faults)

Probable Cause	Remedy
No power to ramp activation button	Is the switch in the cab, the main current switch and the battery switch in the control box is switched ON? Check connections, broken wires, motor earth-connection and short circuits
Blown fuse(s)	Is the main fuse still intact? Are the fuses in the control box intact?

HYDRAULIC SYSTEM

Rear ramps fail or are sluggish in operation

Probable Cause	Remedy
Shortage of oil in supply tank	Fill tank to correct level Check for leaks
Air locked in system	Bleed system
Oil blockage (ie. damaged / kinked)	Check for restriction in pipe work, check filter, check control valve

PNEUMATIC SYSTEM

Air neck ramp failure

Probable Cause	Remedy
Insufficient air supply	Build tractor unit air pressure up to 6.5 bar
Pressure protection/charging valve faulty	Should be set to supply 6.0 bar. Reset or replace valve
Clogged air line filter	Clean or replace element
Leak in air lines, connections or air bag assembly	Inspect for damage and test for leaks, locate and repair or replace

PAINT FINISH

Streaky or matt appearance

Probable Cause	Remedy
Attack on pigment by strong acids / alkalis	Check dilution of cleaning solution should not be above pH8 - 9 (see page 60 for further details)
Caustic (burning chemical action) attack on synthetic resins	Too much free caustic present should be <0.5% caustic
Powdery residue when dry, allowing detergent to dry on paint surface	Rinse with plenty of clean cold water; do not let detergent dry on paint surface

USEFUL CONTACTS

Montracon has a dedicated network of service facilities, backed by a comprehensive daily parts service, nationwide.

FOR SERVICE AND/OR PARTS

TELEPHONE: 01302 732500

Ask for service or parts.

Please have the trailer chassis number available.

Montracon



the trailer for road transport



Machinery Carrier

01302 732500

www.montracon.com

**Montracon Ltd, Carr Hill,
Doncaster, DN4 8DE**

Montracon Limited reserves the right to make modifications to the design and/or technical specification of equipment without this resulting in making such modifications to product already sold. Whilst every effort is made to make sure descriptions, illustrations and specifications within this handbook are correct at the time of going to print, these are also subject to change.

© Copyright Montracon 2019

HYDRAULIC POWER PACK

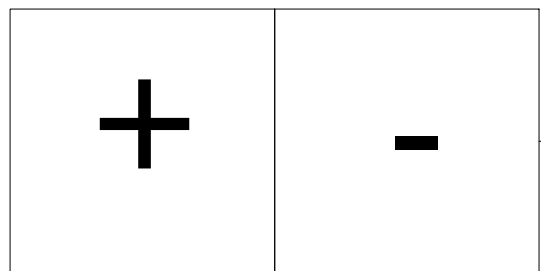

AMD MEGA FUSE
(FITTED TO INNER SIDE OF
THE N/S BEAM)

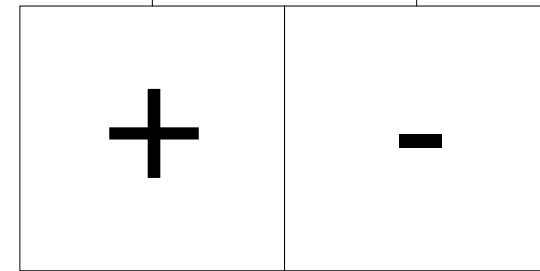
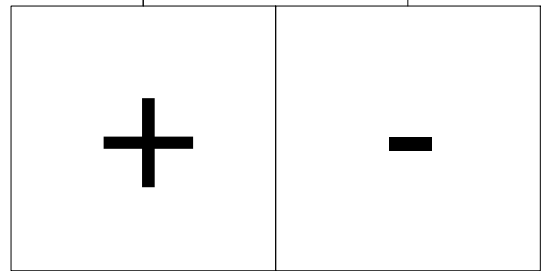
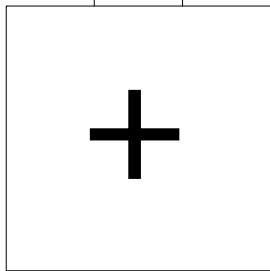
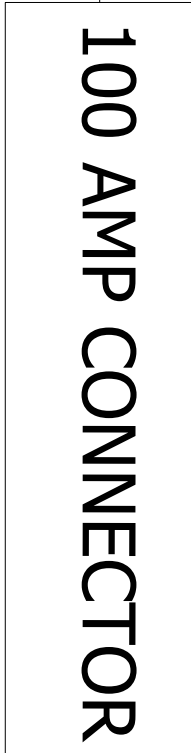

WINCH ISOLATOR

ANDERSON SOCKETS

WINCH

PARTS LIST			
ITEM	QTY	DESCRIPTION	PART NUMBER
1	1	0-376-85 200A FUSE HOLDER	52030510
2	1	0-376-20 200 AMP FUSE	52030512
3	1	4-204-05 ANDERSON CABLE 3M	52031200
4	1	0-431-75 GREY ANDERSON CONNECTOR	52031214

REV	AUTHOR	DESCRIPTION	DATE	APPROVED
A	RJ	FIRST ISSUE	30/09/2024	N/A

<p>CONFIDENTIAL DRAWING © 2024 THIS DRAWING IS THE PROPERTY OF MONTRACON Ltd. IT MUST NOT BE TRACED NOR REPRODUCED IN ANY MANNER NOR SHALL IT BE SUBMITTED TO OUTSIDE PARTIES FOR EXAMINATION WITHOUT CONSENT. IT SHALL BE USED ONLY AS A MEANS OF REFERENCE.</p>		<p>STD TOL'S UNLESS OTHERWISE STATED</p> <table border="1"> <tr> <th>SIZE</th> <th>TOLERANCE</th> </tr> <tr> <td>UP TO 150</td> <td>±0.50mm</td> </tr> <tr> <td>OVER 150 UP TO 500</td> <td>±1.00mm</td> </tr> <tr> <td>OVER 500 UP TO 1000</td> <td>±1.5mm</td> </tr> <tr> <td>OVER 1000</td> <td>±2.0mm</td> </tr> <tr> <td>MACHINE</td> <td>±0.25mm</td> </tr> <tr> <td>ON ANGLES</td> <td>±0.50°</td> </tr> </table>	SIZE	TOLERANCE	UP TO 150	±0.50mm	OVER 150 UP TO 500	±1.00mm	OVER 500 UP TO 1000	±1.5mm	OVER 1000	±2.0mm	MACHINE	±0.25mm	ON ANGLES	±0.50°	<p>DRAWN BY RJ</p> <p>DATE 30/09/2024</p> <p>APRVD BY</p>	<p>Montracon <i>the trailer for road transport</i></p> <p>Carr Hill Doncaster South Yorkshire DN4 8DE Tel: 01302 732500 Fax: 01302 732501</p>	<p>TITLE M3A - WIRING DIAGRAM</p> <p>DO NOT SCALE - IF IN DOUBT ASK</p>
SIZE	TOLERANCE																		
UP TO 150	±0.50mm																		
OVER 150 UP TO 500	±1.00mm																		
OVER 500 UP TO 1000	±1.5mm																		
OVER 1000	±2.0mm																		
MACHINE	±0.25mm																		
ON ANGLES	±0.50°																		
<p>THIRD ANGLE PROJECTION</p>	<p>EDGES AND BURRS MUST BE REMOVED</p>	<p>DATE</p>	<p>MATERIAL</p>	<p>FINISH None</p>	<p>DWG No A-012302-01</p>	<p>SHT 1 OF 1</p>													

A

A